









## ASSEMBLY INSTRUCTION: CABINET QUEEN BED

HARDWARE LIST		QTY
H	METAL SHEET CORNER 	4 pcs
I	SCREW PAN HEAD 4 X 20 	48 pcs
J	CASTER 	2 pcs
K	SCREW TAPER HEADS 3.5 X 15 	4 pcs
L	HANDLE FOR DRAWERS 	2 pcs
M	BOLT FOR HANDLE 5/32" X 35 	4 pcs
N	SCREW PAN HEAD 4 X 25 	6 pcs
O	BOLT 06 x 45 	6 pcs
P	ALLEN KEY M4 	1 pcs



# ASSEMBLY INSTRUCTION: CABINET QUEEN BED

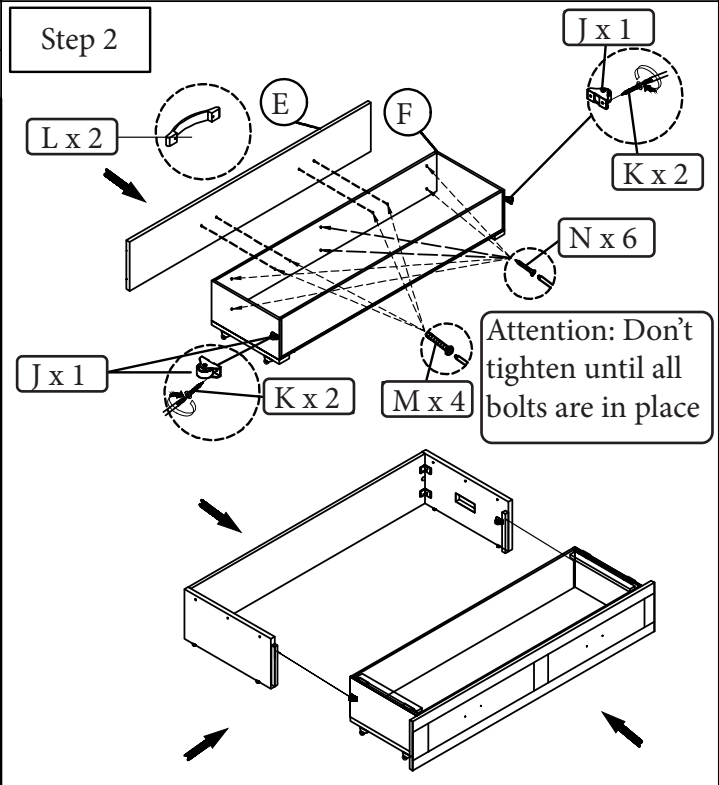
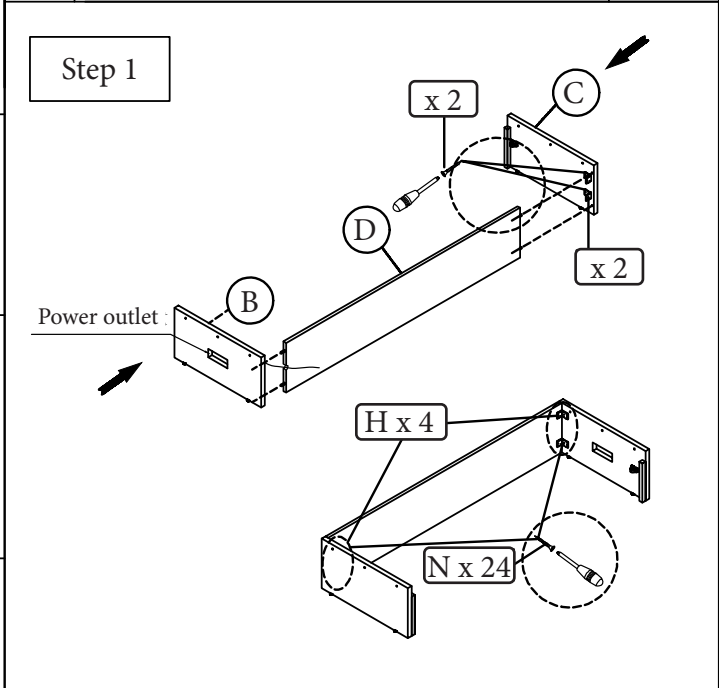
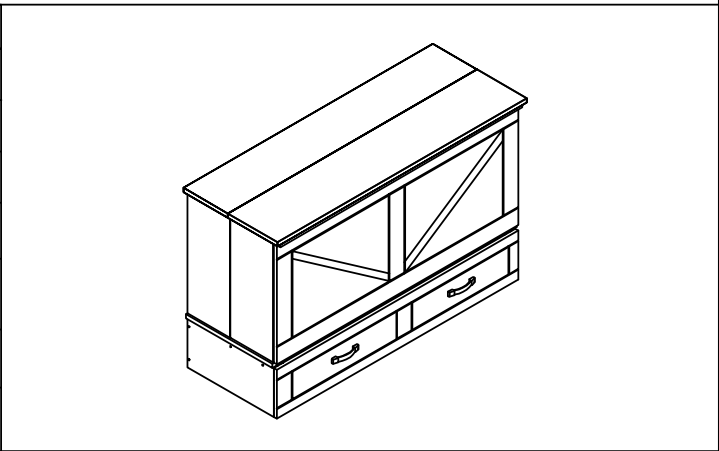