

Wilding Wallbeds

S-200 Vertical **Murphy Bed Mechanism** Cut List & Plans

Style: S-200 Vertical (Metal Rails) Murphy Bed Mechanism
Orientation: Vertical
Size: King, Queen, Full, Twin

WARNING! ALL MURPHY/WALL BED SYSTEMS CONTAIN STORED ENERGY. FAILURE TO USE AND FOLLOW THESE INSTRUCTIONS DURING THE INSTALLATION PROCESS COULD RESULT IN SEVERE PERSONAL INJURY TO THE USER OR DAMAGE TO PRODUCT. PLEASE CONTACT CUSTOMER SERVICE AT 866-725-6401 FOR ANY QUESTIONS.

Page intentionally left blank

Steps to Complete Project

CABINET MATERIAL:

IT IS STRONGLY RECOMMENDED TO CONSTRUCT MURPHY BED CABINET USING 4 X 8 PLY CORE (FURNITURE GRADE) PANELS. MDF MAY BE USED BUT BED MAY BE HEAVY TO OPERATE. PARTICLE BOARD CANNOT BE USED FOR THIS PROJECT.

1. Cut, Mill and Edge band all cabinetry parts as detailed in these instructions.
2. Apply finish as desired to all cabinet parts as indicated in these instructions.
3. Assemble cabinetry components in the room the Murphy Bed is to be used.
4. Anchor cabinetry to structural members (i.e. wood studs) in your wall.
5. Familiarize yourself with all of the mechanism components.
6. Install bed rails, and lift mechanism to the cabinetry parts as illustrated in these instructions.

Number of 4 x 8 Panels to Needed:

King Size Bed - 4
Queen Size Bed - 3
Full Size Bed - 3
Twin Size Bed - 2

Hardware to be sourced Locally:

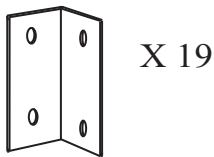

Note: Corner bracket legs can be between .75" and 1.25"
Length can be between 1.5" and 2" long *

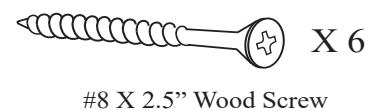
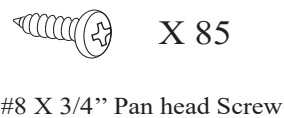
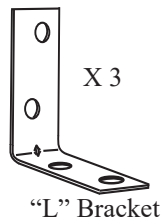

* As an option you may choose to use hardwood corner blocks you cut yourself instead of using locally sourced corner brackets. See pages 12 & 13 for intended use.

King and Queen Cabinet Cut List (Vertical Orientation)

FOR BEST RESULTS IT IS STRONGLY RECOMMENDED TO CONSTRUCT MURPHY BED CABINET USING 4 X 8 PLY CORE (FURNITURE GRADE) PANELS. MDF MAY BE USED BUT KING SIZE BEDS WILL BE HEAVY TO OPERATE. PARTICLE BOARD CANNOT BE USED FOR THIS PROJECT.

<u>King Bed</u>		<u>Overall Cabinet Dimensions</u>		
Mattress Size: 76" x 80" 12" Max thickness		81 1/2" w x 88 1/4" h 16" d Protrusion from wall: 90 Cabinet Material: 3/4" Ply core or MDF Note: MDF will make bed hard to operate. Consider using Ply core for front Panels.		
Quantity	Description	Width	Length	Edge Banding
4	Bed Face Panels	19 7/8"	82 5/16"	All 4 Edges
2	Side Boards	16"	88 1/4"	One long Edge (front)
1	Headboard	14 1/4"	80"	One Long Edge (top)
1	Bridge Board	14 1/4"	80"	No Edge banding
1	Top Fascia	2"	80"	One Long Edge (bottom)
1	Rear Stretcher	6"	80"	One Long Edge (top)
1	Front Stretcher	4"	80"	One Long Edge (top)

<u>Queen Bed</u>		<u>Overall Cabinet Dimensions</u>		
Mattress Size: 60" x 80" 12" Max thickness		65 1/2" w x 88 1/4" h 16" d Protrusion from wall: 90 Cabinet Material: 3/4" Ply core or MDF		
Quantity	Description	Width	Length	Edge Banding
4	Bed Face Panels	15 7/8"	82 5/16"	All 4 Edges
2	Side Boards	16"	88 1/4"	One long Edge (front)
1	Headboard	14 1/4"	64"	One Long Edge (top)
1	Bridge Board	14 1/4"	64"	No Edge banding
1	Top Fascia	2"	64"	One Long Edge (bottom)
1	Rear Stretcher	6"	64"	One Long Edge (top)
1	Front Stretcher	4"	64"	One Long Edge (top)

Full and Twin Cabinet Cut List (Vertical Orientation)

FOR BEST RESULTS IT IS STRONGLY RECOMMENDED TO CONSTRUCT MURPHY BED CABINET USING 4 X 8 PLY CORE (FURNITURE GRADE) PANELS. MDF MAY BE USED BUT BED MAY BE HEAVY TO OPERATE. PARTICLE BOARD CANNOT BE USED FOR THIS PROJECT.

<u>Full Bed</u>		<u>Overall Cabinet Dimensions</u>		
Mattress Size: 54" x 75" 12" Max thickness		59 1/2" w x 83 1/4" h 16" d Protrusion from wall: 85 Cabinet Material: 3/4" Ply core or MDF		
Quantity	Description	Width	Length	Edge Banding
4	Bed Face Panels	14 3/8"	77 5/16"	All 4 Edges
2	Side Boards	16"	83 1/4"	One long Edge (front)
1	Headboard	14 1/4"	58"	One Long Edge (top)
1	Bridge Board	14 1/4"	58"	No Edge banding
1	Top Fascia	2"	58"	One Long Edge (bottom)
1	Rear Stretcher	6"	58"	One Long Edge (top)
1	Front Stretcher	4"	58"	One Long Edge (top)

<u>Twin Bed</u>		<u>Overall Cabinet Dimensions</u>		
Mattress Size: 39" x 75" 12" Max thickness		44 1/4" w x 83 1/4" h 16" d Protrusion from wall: 85 Cabinet Material: 3/4" Ply core or MDF		
Quantity	Description	Width	Length	Edge Banding
2	Bed Face Panels	21 1/4"	77 5/16"	All 4 Edges
2	Side Boards	16"	83 1/4"	One long Edge (front)
1	Headboard	14 1/4"	43"	One Long Edge (top)
1	Bridge Board	14 1/4"	43"	No Edge banding
1	Top Fascia	2"	43"	One Long Edge (bottom)
1	Rear Stretcher	6"	43"	One Long Edge (top)
1	Front Stretcher	4"	43"	One Long Edge (top)

King Size Bed

Suggested panel layout using 4' x 8' panels

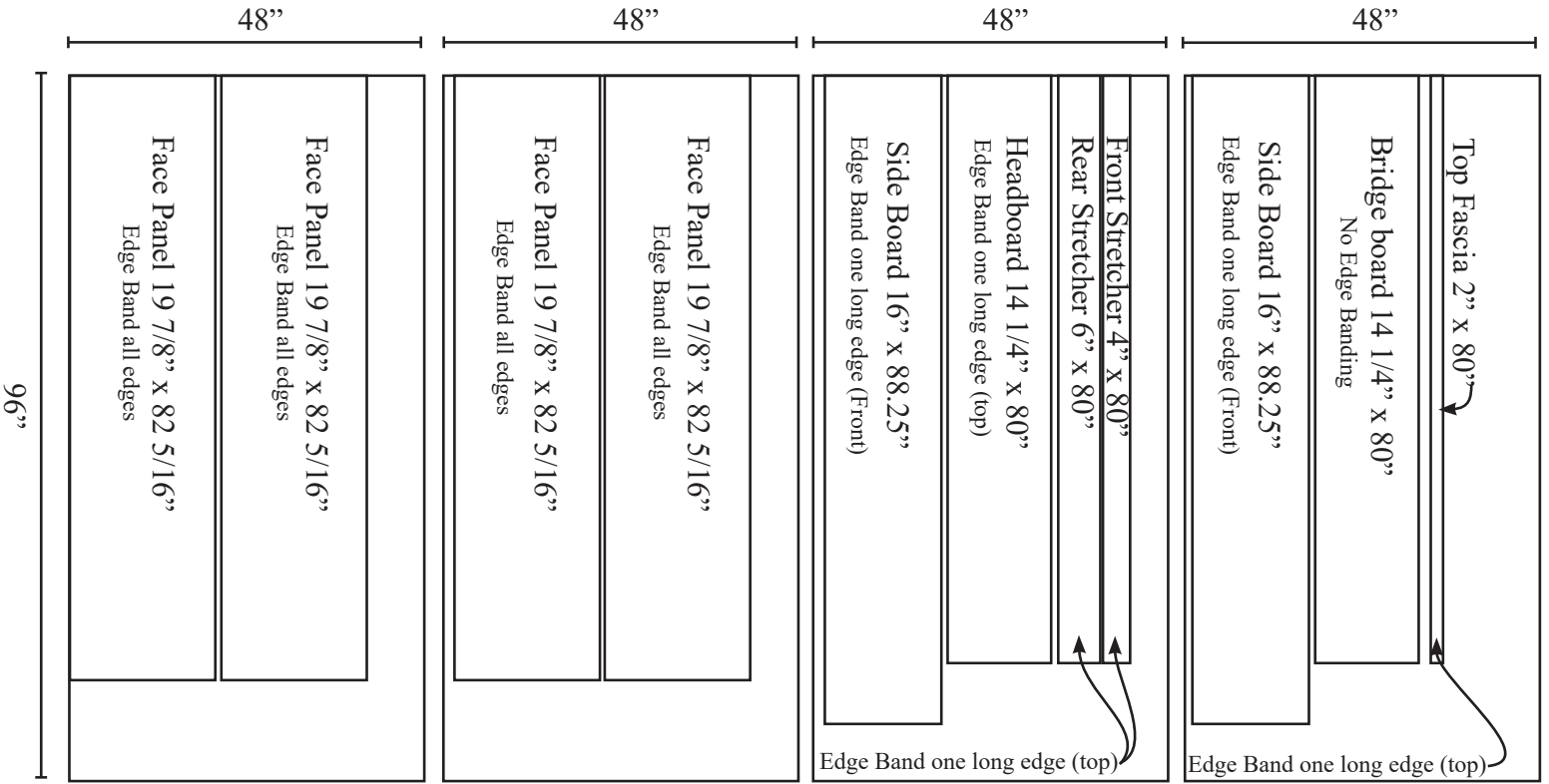

Queen Size Bed

Suggested panel layout using 4' x 8' panels

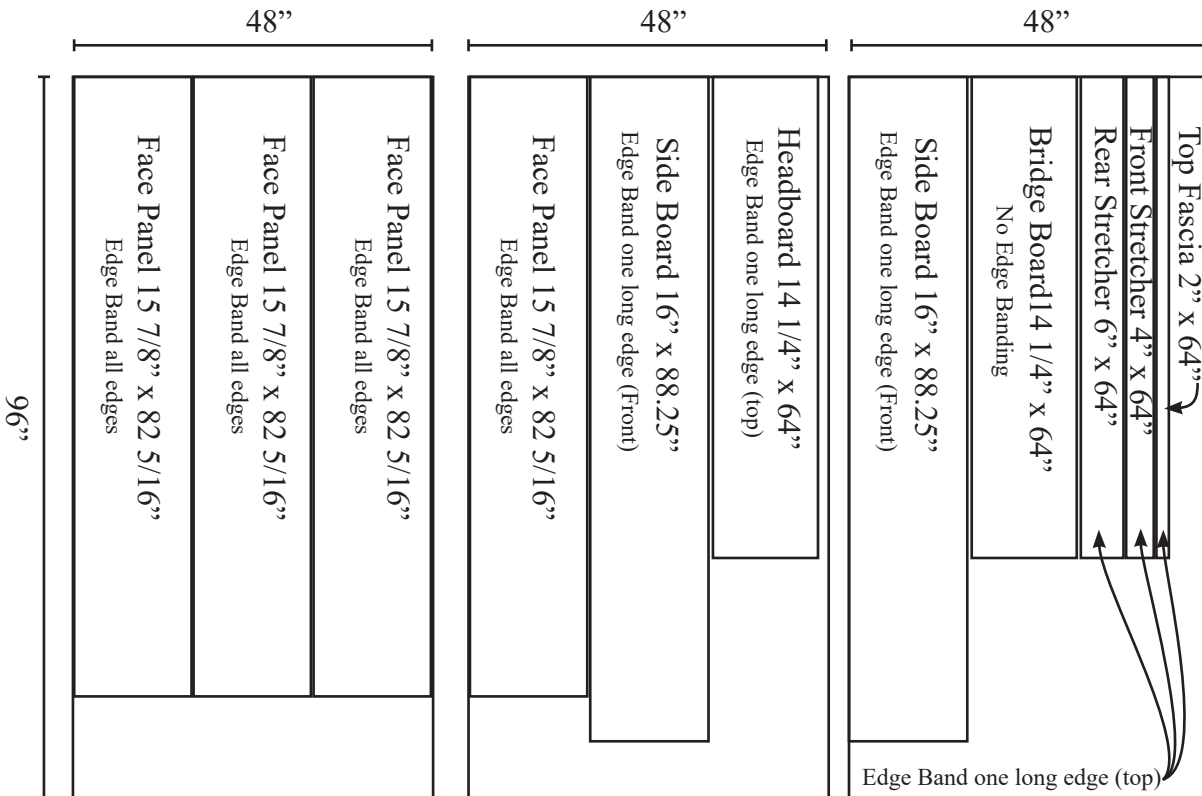

Full Size Bed

Suggested panel layout using 4' x 8' panels

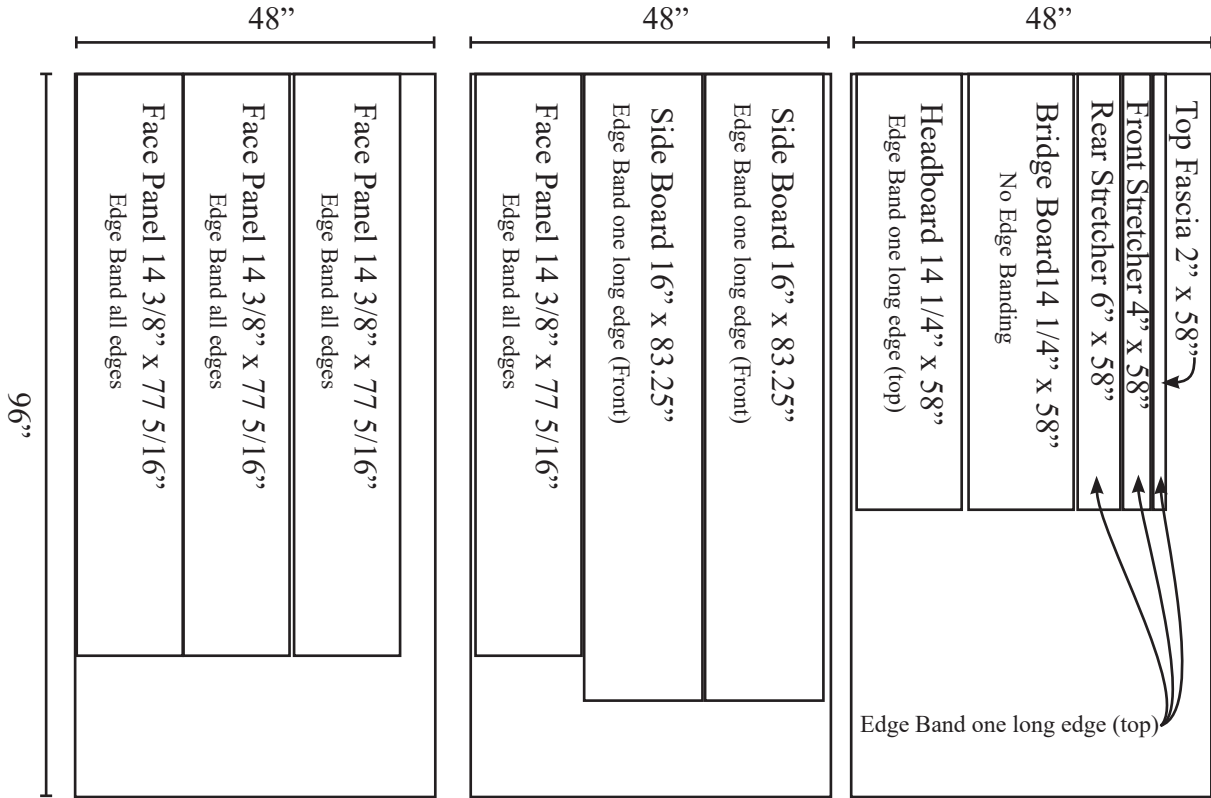

Twin Size Bed

Suggested panel layout using 4' x 8' panels

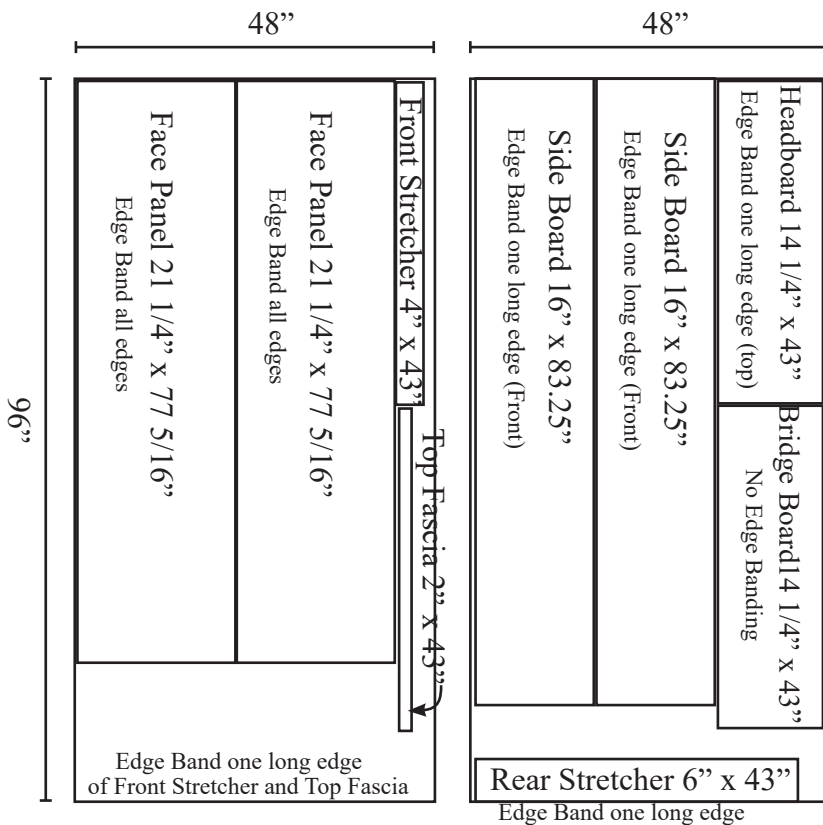

Step 1: Milling Side Boards for Lift Mechanisms

-Drill holes for lift mechanisms in the Side Boards (mirror holes for left and right side boards) by marking exact hole location on the inside side of the Side Boards using illustration below.

- Drill a 1/16" pilot hole for each mounting bolt. Then drill the final hole with a 5/16" bit.

- Countersink 5/8" on the outside of the panels just deep enough for the 5/16" x 1.25" Machine screws. (Found in the Mechanism box Pack 2).

Right Side Board illustrated

(Inside panel side)

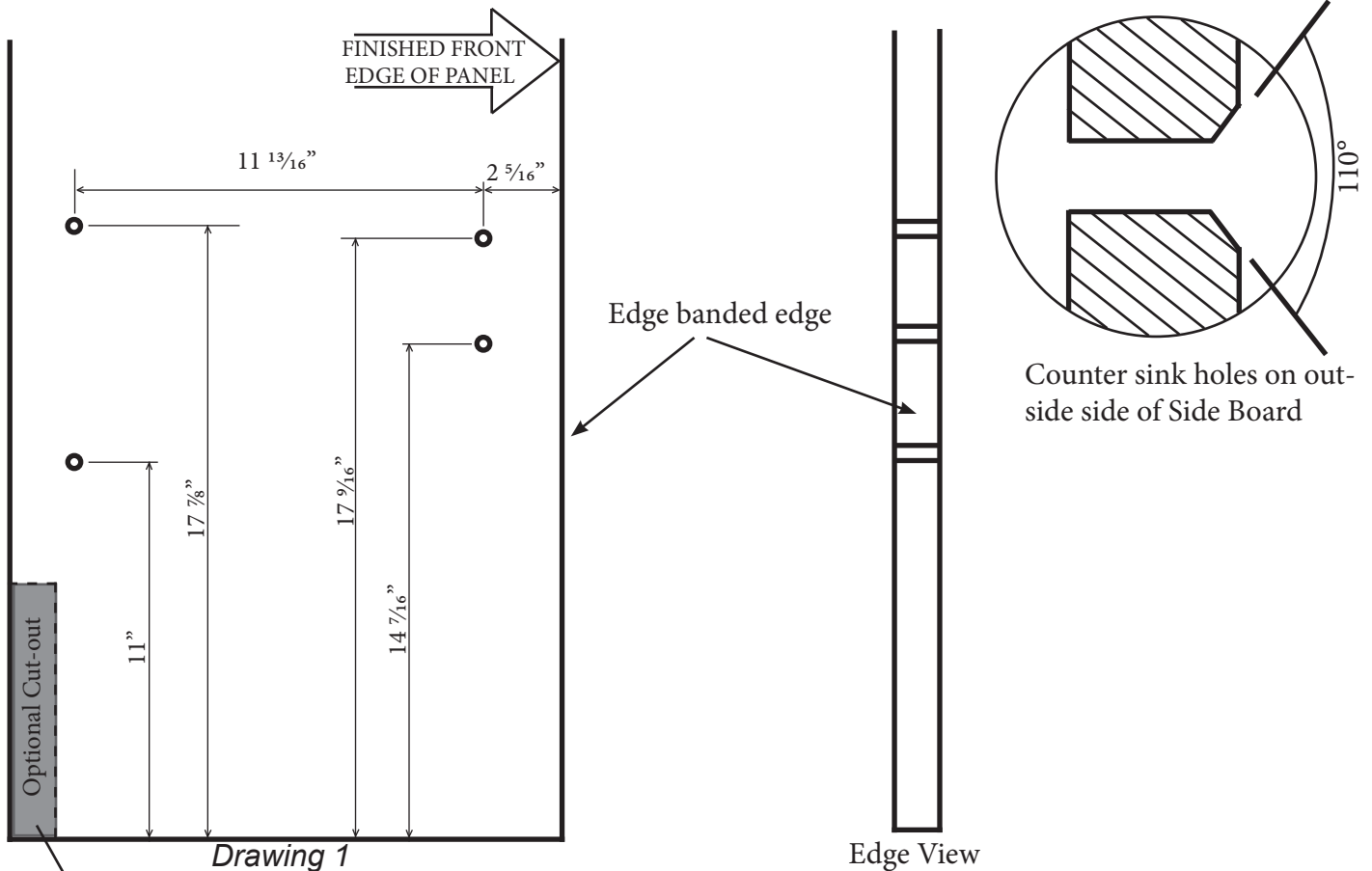

Optional Cut Out for Base Mold in Home

If there is a baseboard on the intended installation wall, there is a option to cut out the back bottom of the Side Board for easy installation. (Recommended)

Maximum cut out not to exceed 1" wide or 9" high. If baseboard exceeds these dimensions baseboard, or baseboard shoe molding will need to be removed during installation process.

Step 2: Apply Stain, Paint and Finish as desired

Finishing Diagram

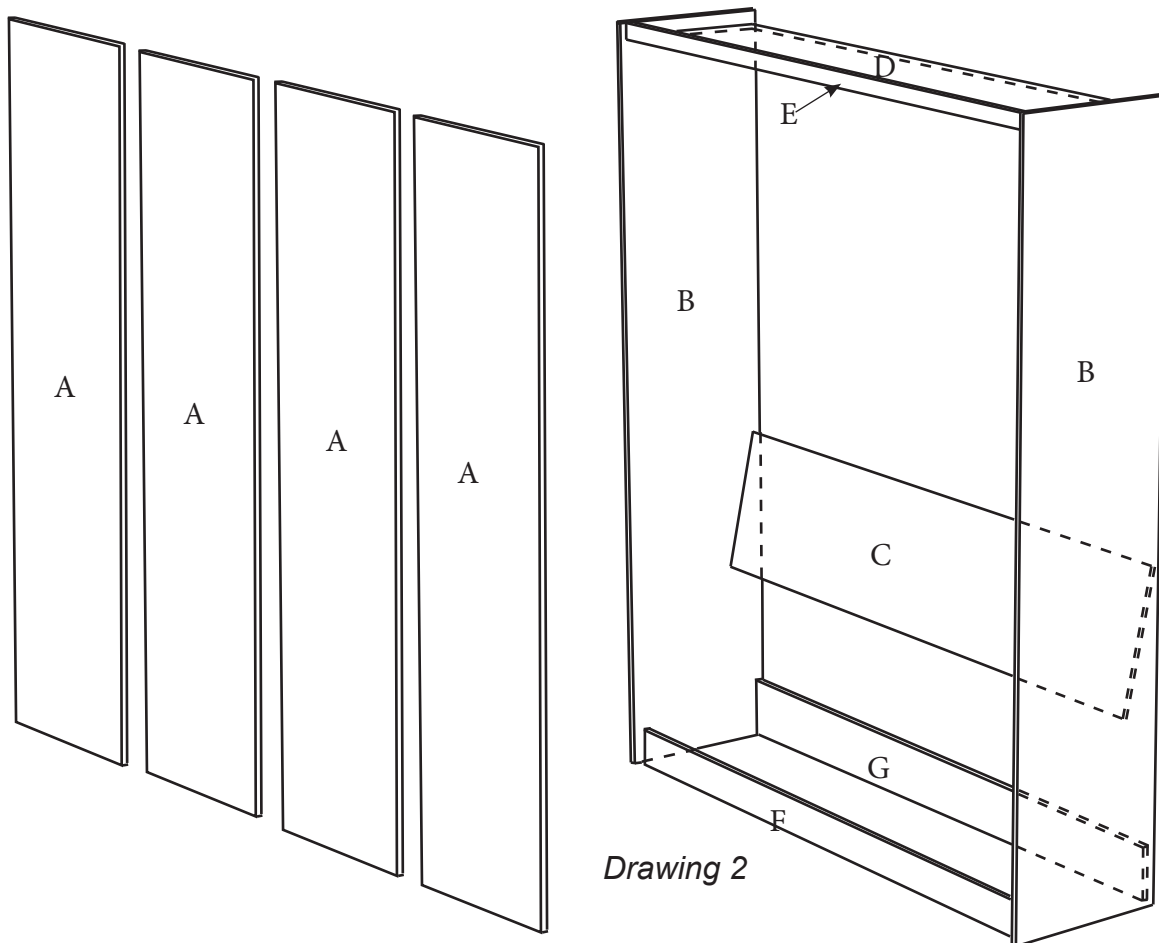

Drawing 2

	Description	Finishing Notes
A	Face Panel	Face Panels are the front of the bed when it is closed. Apply finish to all face panel fronts, all edges (should be edge banded) and at least 2" around the parameter of each back panel (edge of the back are seen when the bed is being used).
B	Side Board	Side Boards should have finish applied to both sides and the front edge. (should be edge banded).
C	Headboard	Headboard should have finish applied to one side, top edge (should be edge banded). Finish back if desired but won't be visible.
D	Bridge Board	Bridge Board should have finish applied to one side. Finish opposite side if desired, but is not typically seen.
E	Top Fascia	Top Fascia should have finish applied to one side and edge banded edge. (should be edge banded on bottom edge).
F	Front Stretcher	Front Stretcher should have finish applied to one side and one edge. (should be edge banded).
G	Rear Stretcher	Rear Stretcher should have finish applied to one side and one edge. (should be edge banded).

Tools Needed For Assembly and installation of Cabinet and Lift Mechanism.

Socket Wrench



13mm Socket

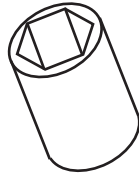

10mm Socket

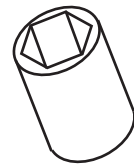

8mm Socket



10/13mm Wrench

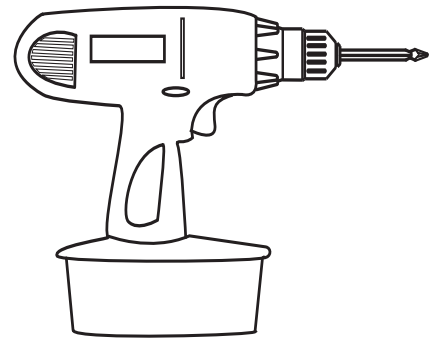
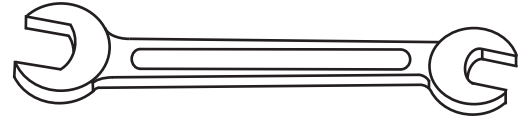

Cordless screw driver
With Phillips bit

Tape Measure

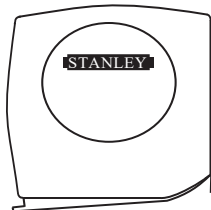

Stud Finder

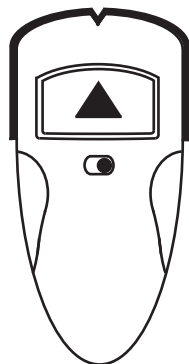



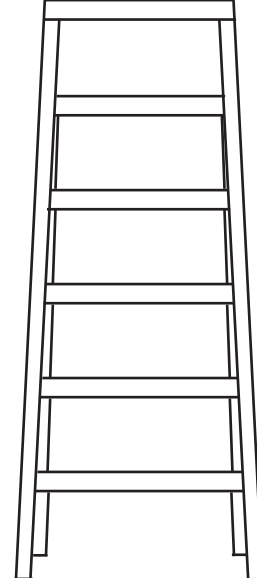

6-foot Ladder

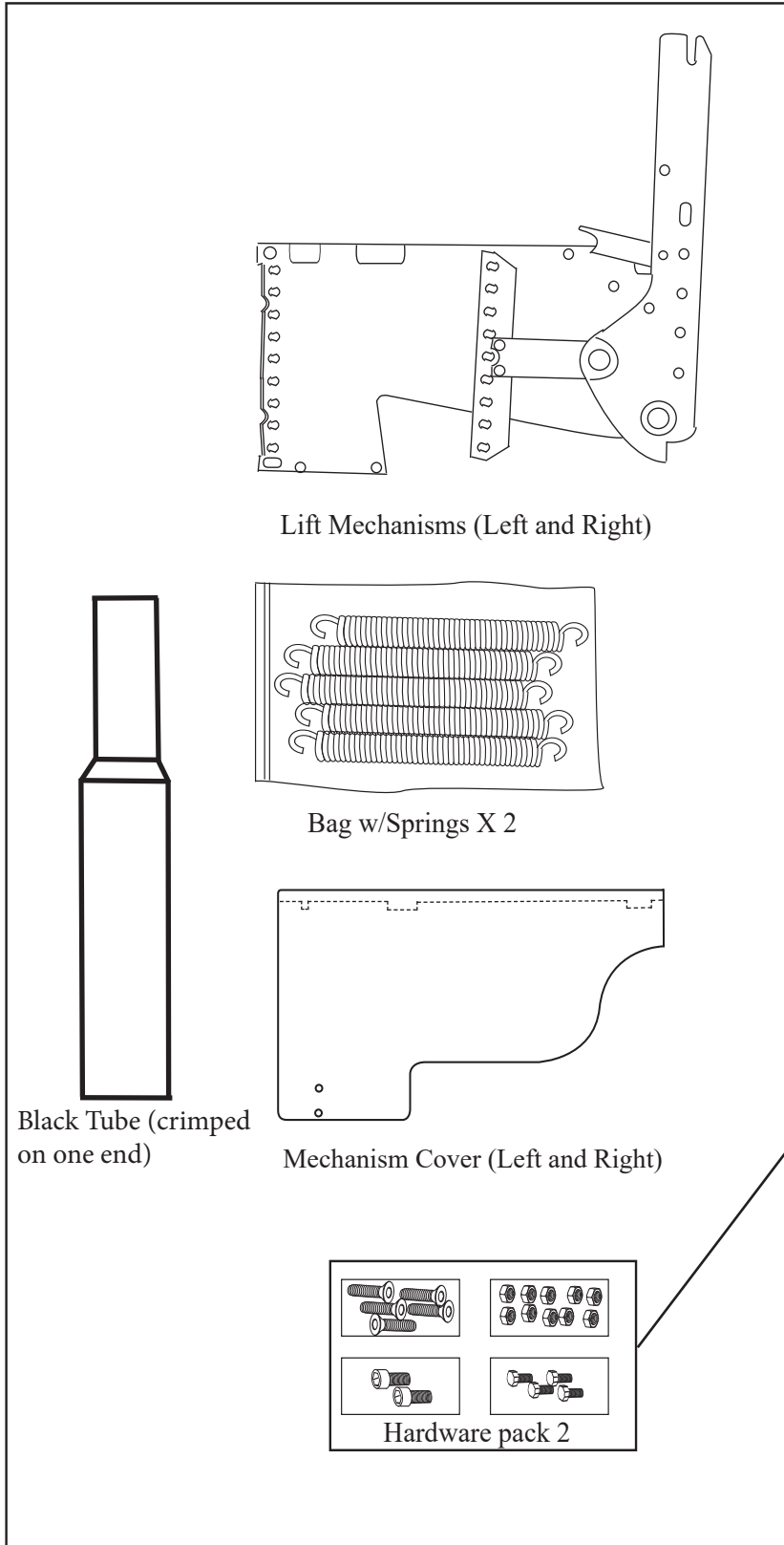

Begin Assembling Murphy Bed

Locate Mechanism box (Labeled SBLM) including Hardware Pack 2

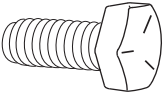
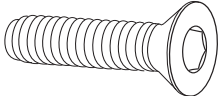
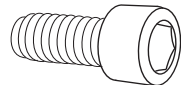

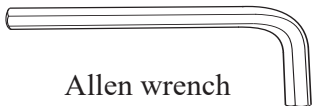
Pack 2	
Item	Qty
 5/16" Nylock Hex Nut	16
 5/16" x 1" Hex Head Bolt	4
 5/16" x 1 1/4" Tapered Allen Head Bolt	10
 5/16" x 1" Allen Head Bolt	2
 1 5/8" Pan head Wood Screw	2
 Allen wrench	

Hardware needed for next step:



(From box labeled SBLM)

Step 3: Installing the Springs

Bed Size	Number of Springs	
	Ply core	MDF
King	8	9
Queen	7	8
Full/Double	5	6
Twin/Single	3	4

The required number of springs in the Lift Mechanisms varies with the different size Murphy Bed, material used and mattress weight. These values are approximate.

King Size Bed Install a spring into hole 5 by hooking one end of the spring into the hole on the Upturned edge of the mechanism plate first then manipulate the Lift Arm back and forth slightly while placing the other end of the spring in the Tension arm into the corresponding hole. Now place a spring into the following holes in this order 4, 3, 2, 1 then into holes 6, 7, 8, 9. You will need a total of 9 springs installed for a King size bed.

Queen Size Bed Install a spring into hole 5 by hooking one end of the spring into the hole on the Upturned edge of the mechanism plate first then manipulate the Lift Arm back and forth slightly while placing the other end of the spring in the Tension arm into the corresponding hole. Now place a spring into the following holes in this order 4, 6 then into holes 3, 7 then 2, 8. You will need a total of 7 springs installed for a queen size bed. MDF add one more spring per side.

Full Size Bed Install a spring into hole 5 by hooking one end of the spring into the hole on the Upturned edge of the mechanism plate first then manipulate the Lift Arm back and forth slightly while placing the other end of the spring in the Tension arm into the corresponding hole. Now place a spring into the following holes in this order 4, 6. Then 3, 7. You will need a total of 5 springs installed for a full size bed. MDF add one more spring per side.

Twin Size Bed Install a spring into hole 5 by hooking one end of the spring into the hole on the Upturned edge of the mechanism plate first then manipulate the Lift Arm back and forth slightly while placing the other end of the spring in the Tension arm into the corresponding hole. Now place a spring into the following holes in this order 4, the holes 6. You will need a total of 3 springs installed for a twin size bed. MDF add one more spring per side.

HELPFUL HINT: Watch how to do this step at:
https://youtube/2C_Exc_pO-8

Or use the camera on your phone to view this step.

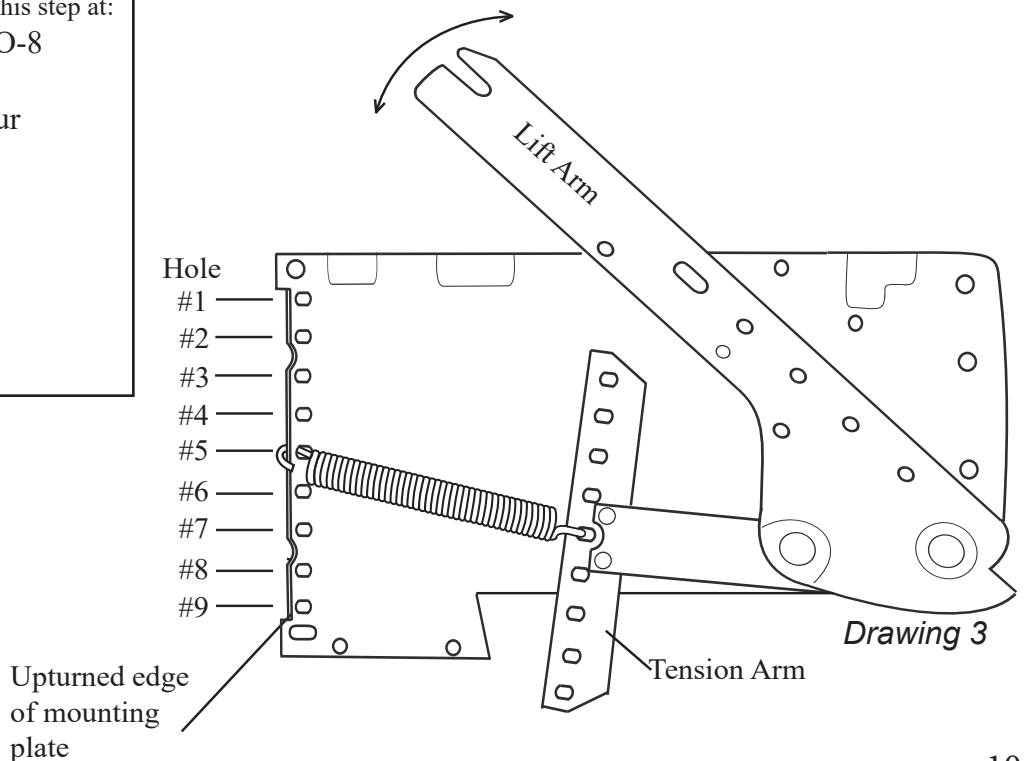

Hardware needed for next step from Pack #2



X 6

5/16" Nylock Nut

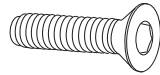

X 8

5/16" x 1 1/4"

Tapered Allen Head Bolt

Step 4: Installing the Lift Mechanism

Install the Lift Mechanism to the Side Board first by inserting a 5/16 x 1 1/4" Tapered Allen Head Bolt through holes B, C and D from the outside (countersunk holes) of the Side Board. The bolts go through the corresponding holes of the Lift Mechanism. Now thread a bolt into hole A as illustrated. Thread on three 5/16" Nylock nuts and tighten hardware. Hole "A" has a threaded collar instead of a nut.

IMPORTANT! Over tightening the bolts will pull the head of the bolt too deeply into the Side Board. Tighten only until the head of the bolt is flush with the surface of the Side Board.

Repeat step 3 with the Left Side Board and Lift Mechanism.

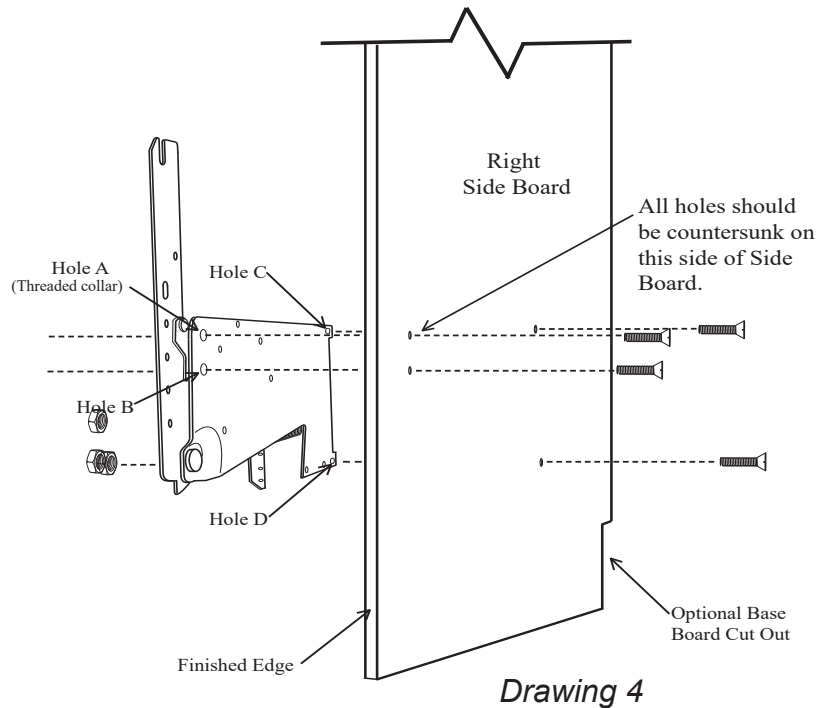

Hardware needed for next step (Supplied Locally)

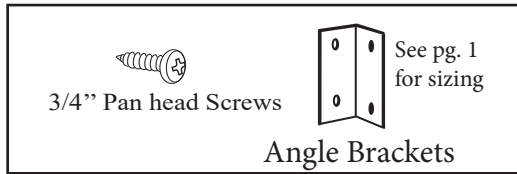

OR

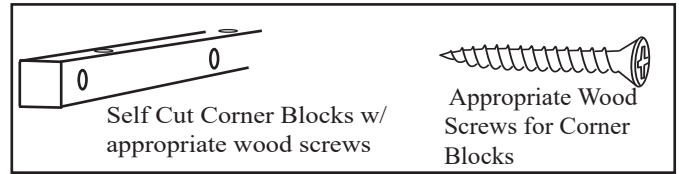

Step 5: Assembling the Bed Cabinet Surround

Bed Cabinet should be assembled in the room where it will be used

1. Locate the mounting position of the Headboard marking the left and right Side Boards 20" from the floor and 3" in from the back edge of the Side Boards See Drawing 8. Note from Drawing 8 that the Headboard sits at an angle and the bottom edge of the Headboard is out 3" from the back of the Side Boards. Use Corner Brackets or Corner Blocks (supplied locally) . Note that the Angle Bracket or Corner Block cannot protrude beyond the back of the Side Boards. The Headboard location may vary slightly; just be sure it is secure and at the approximate 3" distance from the back edge.
2. Use Angle Brackets or Corner Blocks to assemble Front and Back Stretchers in positions shown in Drawings 5, 7, & 8. Use two Angle Brackets or Corner Blocks on each end. Note the Front Stretcher is 1" back from the front edge of the Side Boards.
3. Attach Bridge Board as shown in Drawings 5 & 8. Be sure back edge of the Bridge Board is flush with back of Side Boards and 1 1/4" down from the top of the Side Boards so it is flush with the bottom edge of the Top Fascia. The Top Fascia will cover the front edge of the Bridge Board.
4. Attach the Top Fascia to the front edge of the Bridge Board using Angle Brackets or Corner Blocks as shown in Drawing 5 & 8. Note the Top Fascia covers the front edge of the Bridge Board and is flush with the bottom. The Top Fascia should be 1" back from the front of the Side Boards.

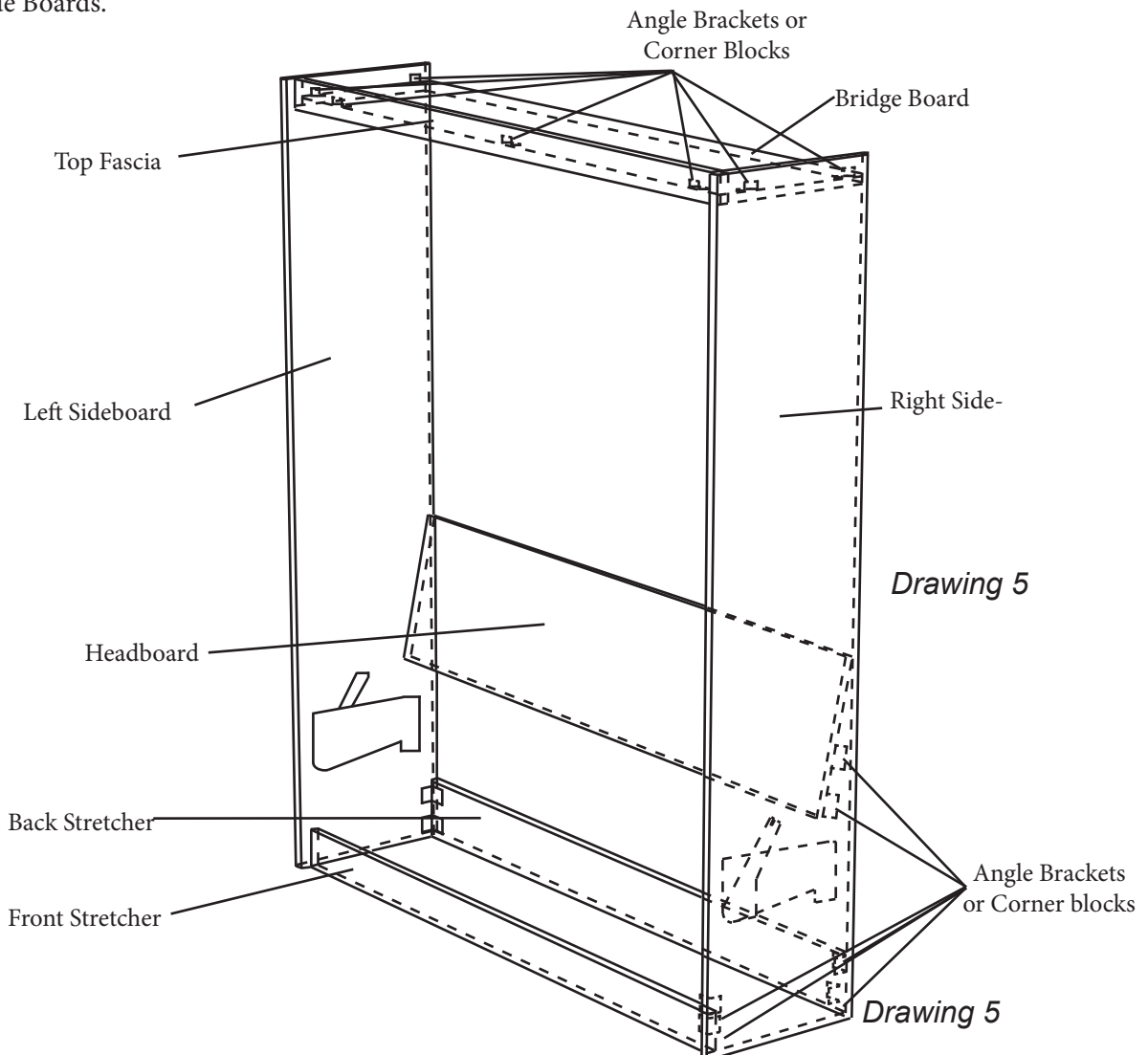

Step 5 Drawings Continued

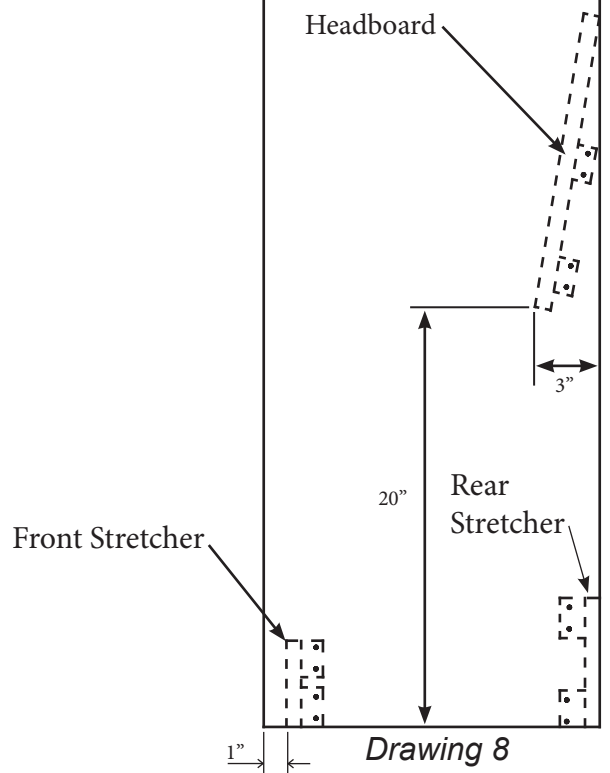
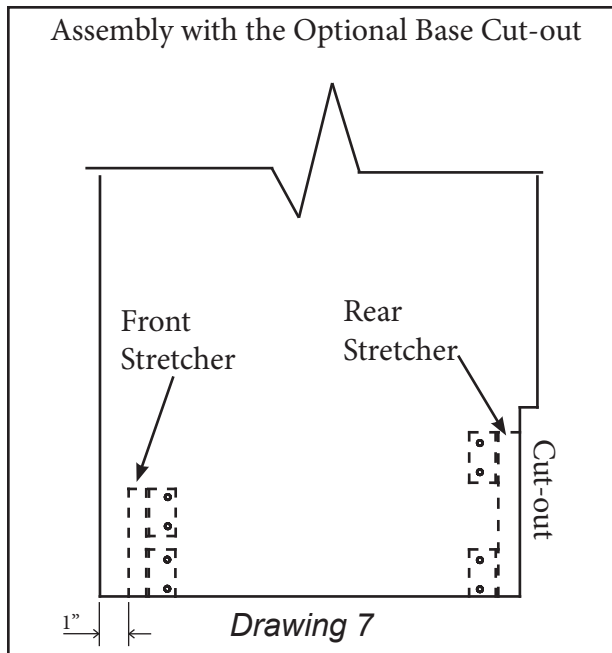
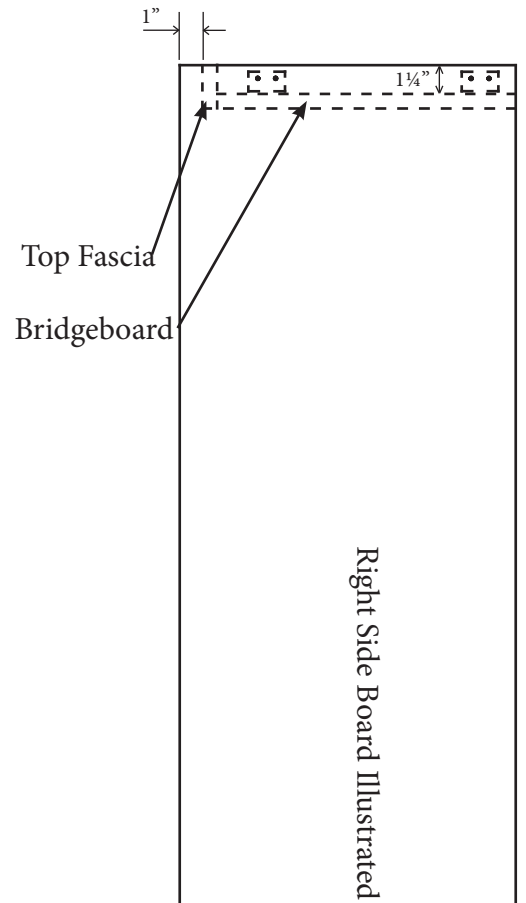
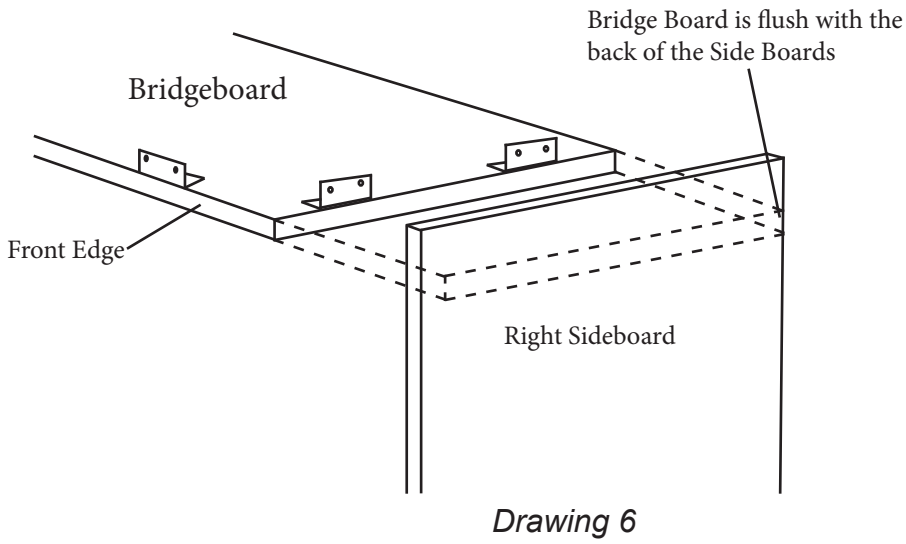

WARNING! THE NEXT STEP MAY REQUIRE PROFESSIONAL HELP.

IF YOUR WALLS ARE NOT TRADITIONAL WOOD FRAMING, YOU MAY NEED TO HIRE A HANDY MAN OR CONTRACTOR TO HELP IN ANCHORING THE BED TO YOUR WALL. FAILURE TO PROPERLY ANCHOR CABINET COULD CAUSE SEVERE PERSONAL INJURY. CALL TECHNICAL SUPPORT AT 866-725-6401 IF YOU HAVE ANY QUESTIONS.

Hardware needed for next step

(Supplied Locally)

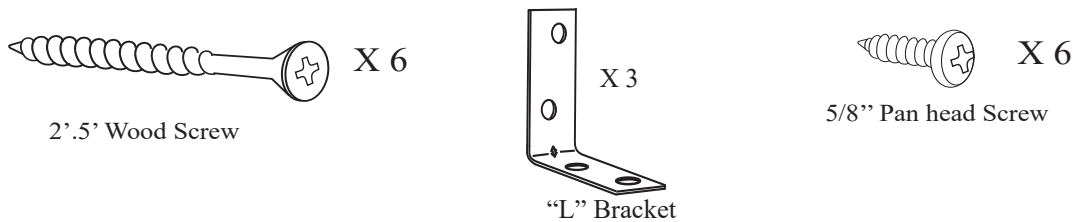

Step 6: Installing the Bed Cabinet Surround to the Wall

Using a Stud Finder locate and mark the studs in your wall directly above the Bed Cabinet. Attach "L" brackets to the top, back of the Bed Cabinet using 5/8" Pan Head screws corresponding to where the studs are located in your wall. Now attach the "L" brackets to the studs in the wall using six 2.5" wood screws. See illustration 6

IMPORTANT! King, Queen and Full size beds require 3 studs, Twin size beds require 2 studs. It is VERY important that the bed cabinet be anchored securely to the wall. If the bed is not anchored properly the Bed Cabinet will fall causing death or serious injury. For technical support call 866-725-6401 toll free.

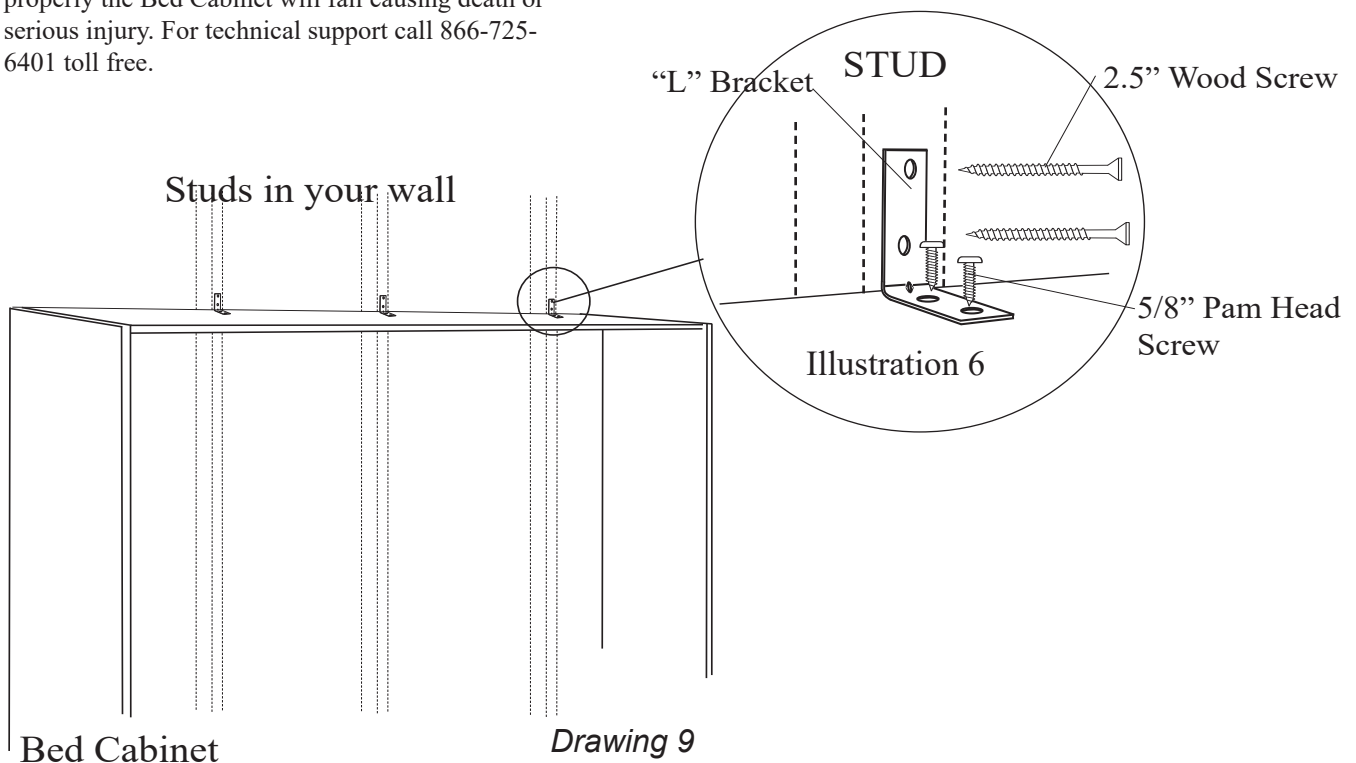





List of Contents from Rail Box

Labeled Panel Bed Steel Frame
BED RAILS, STIFFENERS, AND LEGS LOCATED IN BOX:





Qty.	Frame Carton Items	Comments
2	Head(1) Foot(1) Rails	Identical Head & Foot King Length 77-3/8" Queen Length 61-7/16" Full Length 55-3/8" Twin Length 40-7/16"
2	Side Rails	Identical Right & Left (Longest rails) King Length 80-15/16" Queen Length 80-15/16" Full Length 75-15/16" Twin Length 75-15/16"
3 (5)	Stiffeners	U Shaped mental lengths 3 for Q,F,T (King) size
2	Folding Legs	One Left - One Right
1	Leg Connector Bar	Round bar Stabilizes and Eases Leg Operation

HARDWARE PACKS LOCATED IN BOX:



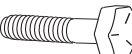

Pack 3

Item	Qty
	16
10-24 Black Nylock Nut	
	2
10-24 x 1/4" Black Machine Screw	
	14
10-24 x 1/2" Black Machine Screw	
	2
1/2" x 3/4" Black Barrel (Leg Stop)	
	4
1"x 1" x 1 3/4" Four Hole Corner Bracket	

Pack 4

Item	Qty
	2
Star Washer	
	2
1/4" x 1 1/2" Hex Head Bolt	
	4
1 1/2" Nylon	
	2
1 1/2" x 5/16" Black washer	
	2
1 1/2" X .765" Black washer	

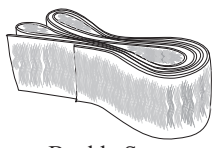
Pack 5

Item	Qty
	2
5/8" Pan head Screw	
	2
3/4" Washer	
	1
Buckle Strap	
	1
Allen Wrench	

Pack 7

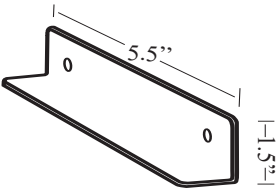
Item	Qty
	160
5/8" Pan head Screw	
-King Size includes 2 Bags	
	2
Panel Saver	

Important note: It is critical to orient the Bed Face panels and the Mattress Rails in the next 6 steps correctly. All of the drawings in the next 6 steps assume that you are looking away from the wall you just installed the Bed Cabinet against in the previous step. There is noted under each of the following renderings indicating “your bed cabinet installed on this side” which indicates that is where the Bed Cabinet is in relation to the face panels and rails.

Step 7 : Assembling the Bed Face

Lay the Face Panels on the floor FACE DOWN (finished side). Position them in front of where the Bed Cabinet was installed in the last step and leave enough room to work around them.

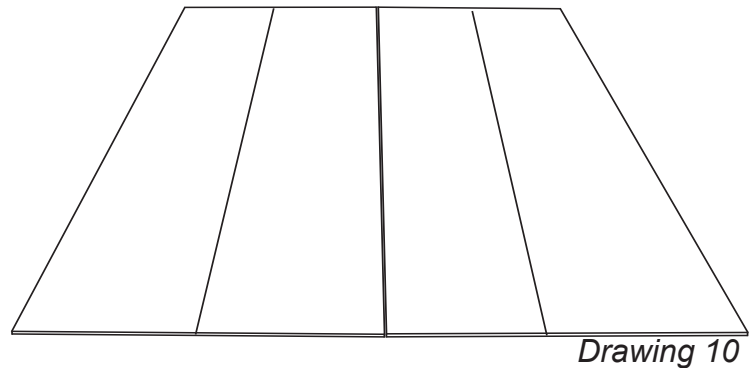

Your bed cabinet is installed on this side

Locate parts for next step from box labeled
Panel Bed Steel Frame



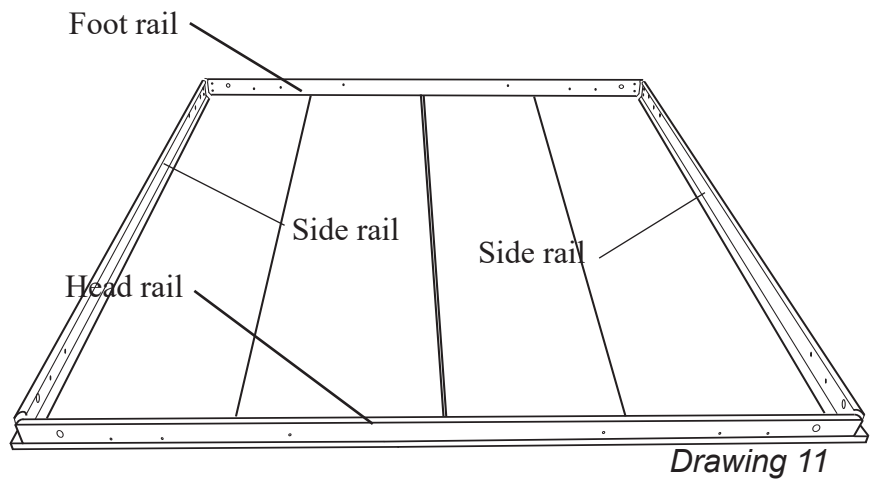

Arrange the Mattress Rails on the face panels as shown.

HELPFUL HINT: the “Head Rail” refers to the end that is closest to the Bed Cabinet during assembly and will be where your head is while sleeping.



Your bed cabinet is installed on this side

Hardware needed for next 2 steps most from Pack #3

-  X 4
4 hole corner bracket
-  X 2
1/2" x 3/4"
Black Barrel
(Leg Stop)
-  X 2
10-24 x 1 1/4" Black
Machine Screw
-  X 14
10-24 x 1/2" Black
Machine Screw
-  X
10-24 Black
Nylock Nut

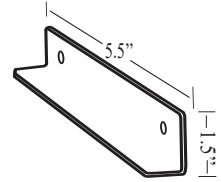

Panel Saver
(From rails box)

Step 8: Assembling the Bed Face (Continued)

From hardware pack 3 locate the hardware shown above. Finger tighten the hardware as shown in illustration 7 connecting the Foot Rail to the Side Rail using the 4 hole corner bracket. Note the lower hole on each Side Rail uses the Leg Stop with the longer screw (1 1/4" Machine). Repeat step on the opposite Side Rail corner.

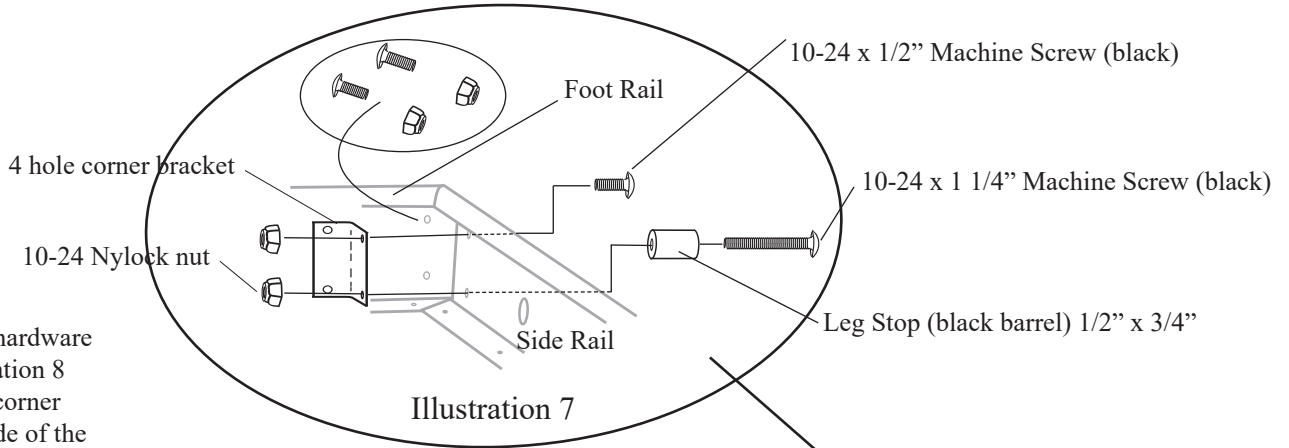

Finger tighten the hardware as shown in illustration 8 attaching a 4 hole corner bracket on the inside of the Side Rail and the Panel Saver on the outside of the Side Rail. Now connect the Head Rail to the Side Rail via the 4 hole corner bracket and repeat on the opposite Head Rail corner.

Once all sides are finger tight go back and tightened all hardware using either a socket or wrench and a Phillips screw driver.

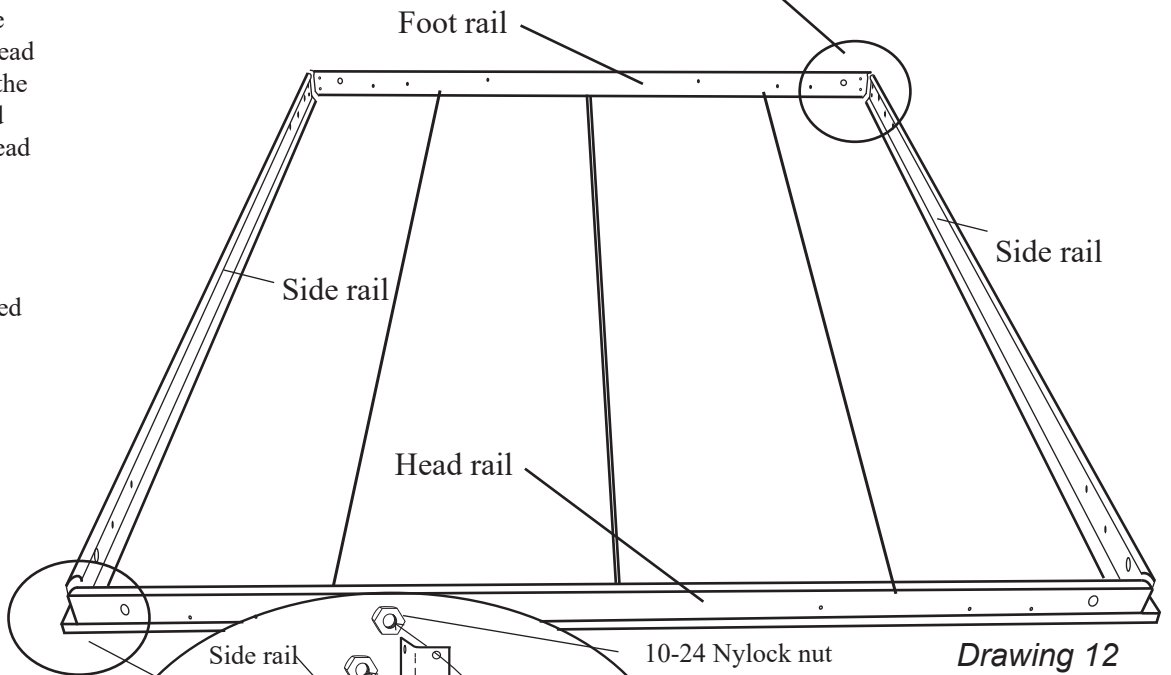

No Hardware used in this hole

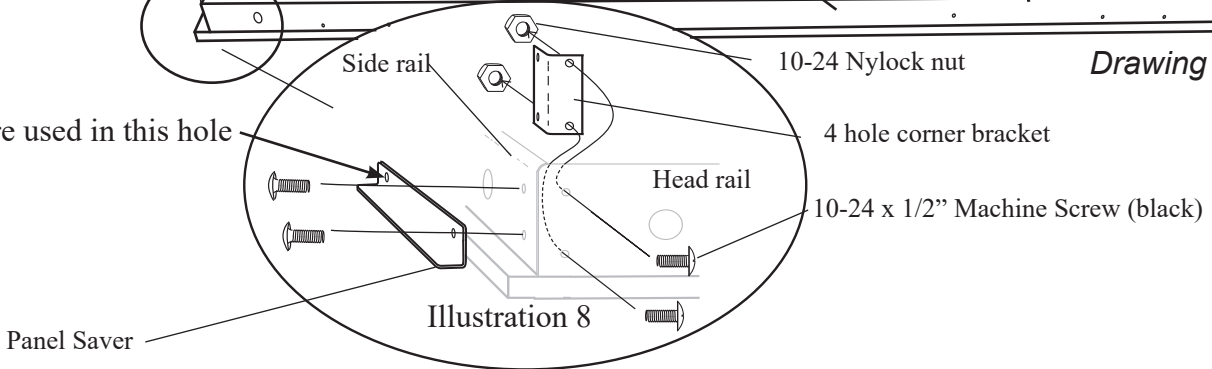

Hardware and parts needed for next steps



X Approx. 118

5/8" Pan head screw
(Hardware pack #7)

Step 8: Assembling the Bed Face (Continued)

Center the assembled frame side to side on the face panels (leaving approximately 1" space on either side) and bring the Head Rail flush to the end of the Face Panels. Once the frame is positioned correctly and the panels and rails are even and square to each other use 2 screws in each corner, 1 in each panel's Head and Foot rail, and 1 in the middle of each Side Rail as illustrated to hold assembly in place. With the rails held in place, use 5/8" screws in each of the remaining holes around the frame.

Caution: DO NOT STRIP SCREW!

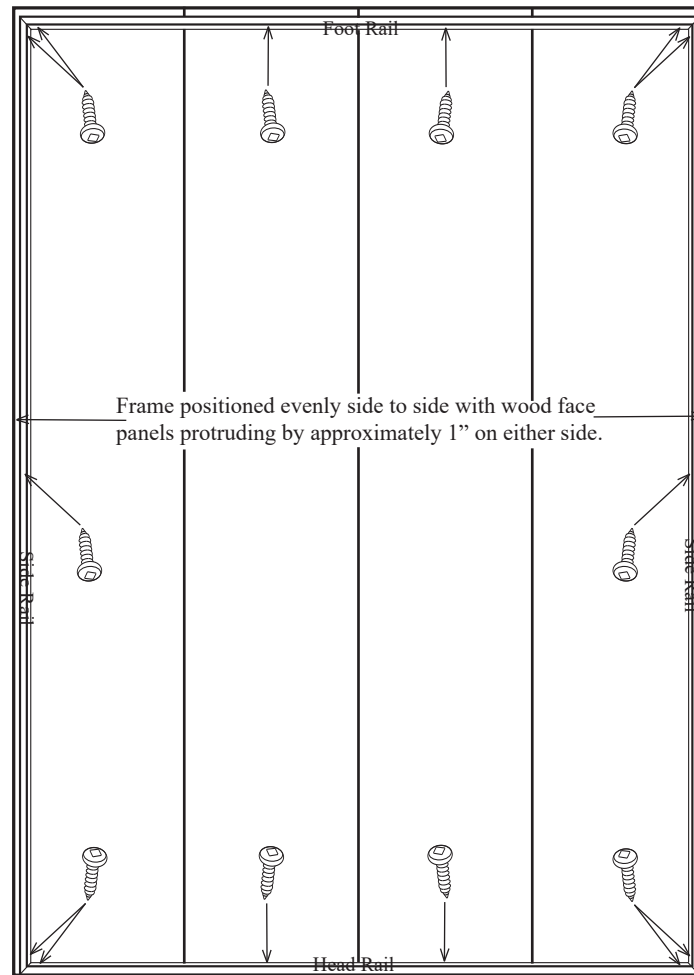

Drawing 13

Frame Head Rail is
flush with face panels

BIRDS EYE (TOP) VIEW

QUEEN, FULL AND TWIN SIZE BEDS

See KING SIZE on next page

Hardware and parts needed for next steps

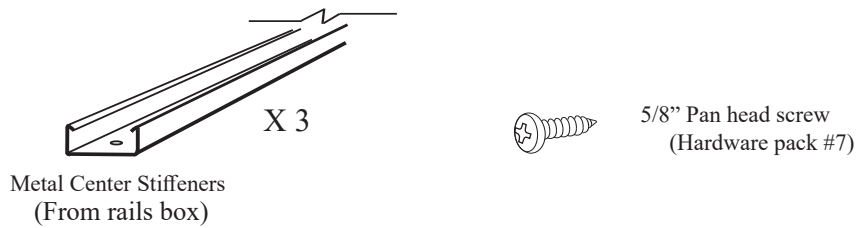

Step 9: Assembling the Bed Face Queen, Full and Twin (Continued)

Position the 3 Metal Stiffeners evenly in the space provided between the Head and Foot Rails as illustrated below. Now use the 5/8" screws to fasten the Stiffeners to the Face Panels using all provided holes in the Stiffeners. **DO NOT STRIP SCREWS.**

Note: Occasionally one of the holes in the Center Stiffeners will be positioned where the seam of the face panels come together. In this case you do not need to put a screw in where it will wedge between two panels.

FOR KING SIZE SEE NEXT PAGE

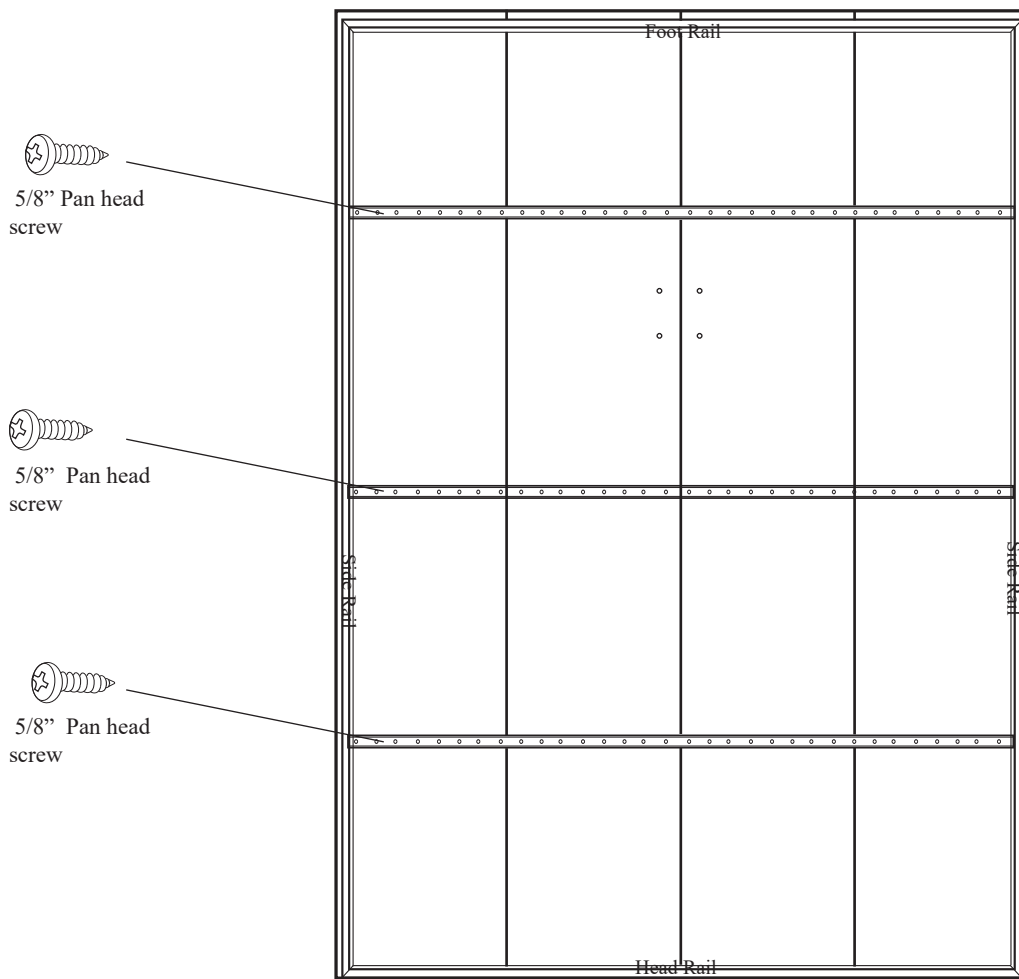

BIRDS EYE (TOP) VIEW

KING SIZE BED ONLY LAYOUT

Hardware and parts needed for next steps

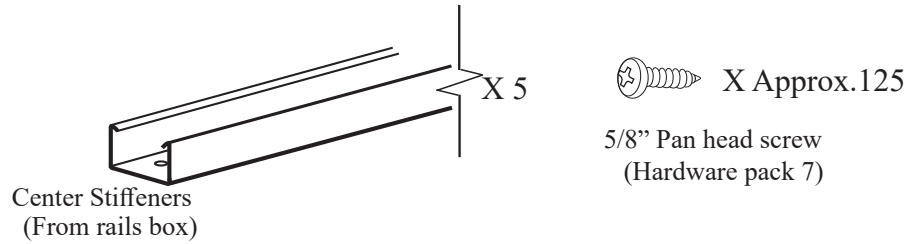

Step 9: Assembling the Bed Face KING SIZE ONLY (Continued)

On a king size frame, place the five Center Stiffeners across the backs of the Face Panels as illustrated below. The Stiffeners will overlap the bottom flange of the Side Rails. Note Stiffener #1 (near the foot rail) is positioned 3.5" from the end of the METAL FRAME so that the center of the Stiffener lines up with the 5/8" hole in the Side Rails. Stiffener #2 butts up against stiffener #1 and Stiffeners #3-5 are spaced evenly in the remaining space.

With the remaining 5/8" Pan head screws from hardware pack 7 attach the center stiffeners to the backs of the Face Panels through all of the provided holes in the stiffeners. **DO NOT STRIP SCREWS.**

Note: Occasionally one of the holes in the Center Stiffeners will be positioned where the seam of the face panels come together. In this case you do not need to put a screw in where it will wedge between two panels.

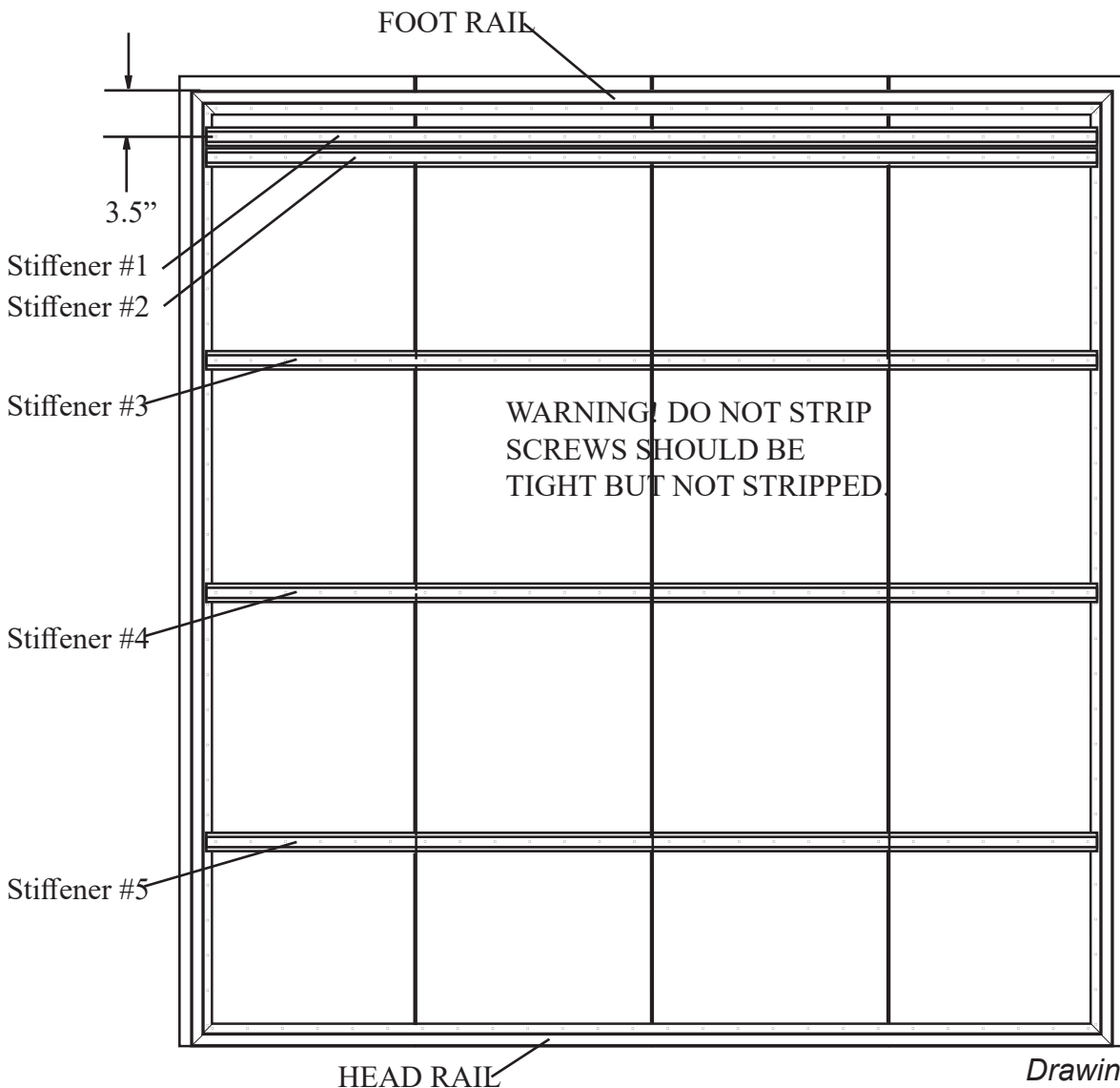

Hardware and parts needed for next steps

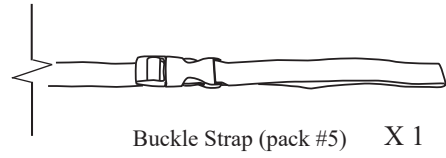
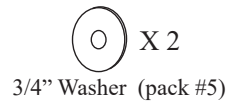

Step 10: Installing the Mattress Strap

Attach the Buckle Strap used for holding the mattress in place when the bed is closed. First remove one of the 5/8" Pan head screws that attaches the rail to the Face Panels on each Side Rail of the frame at about 18" from the Foot Rail. Then put the removed screw through the 3/4" Washer. Position the end of the Strap over the vacated screw hole on the rail and drive the screw through the strap and back into the hole. Repeat the process on the opposite Side Rail.

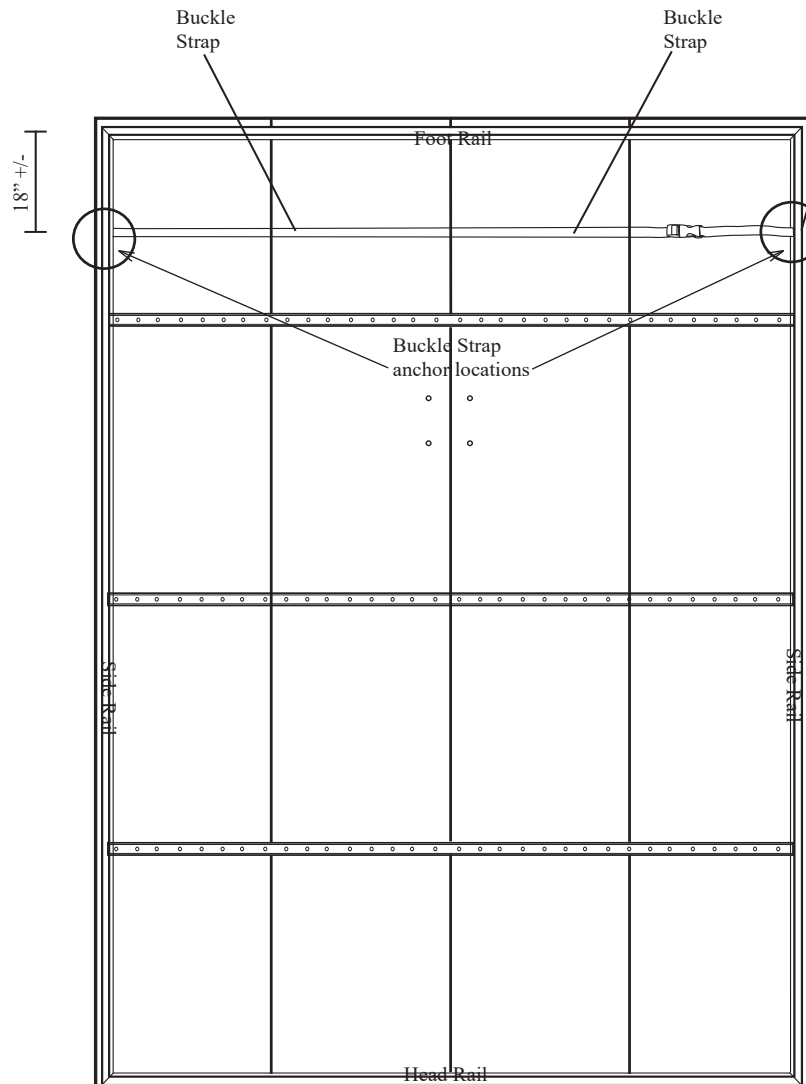
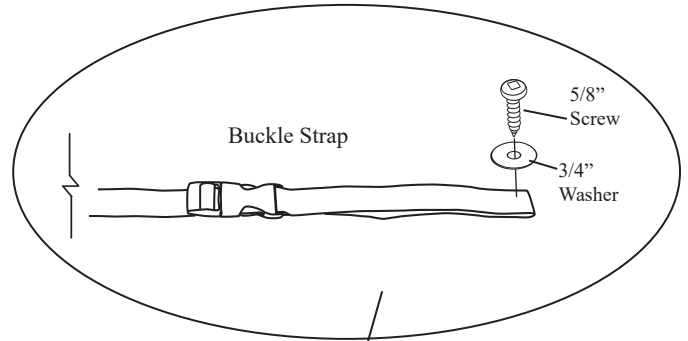

BIRDS EYE (TOP) VIEW *Drawing 16*

Hardware needed for next step from hardware pack #2

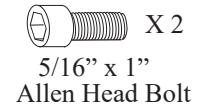
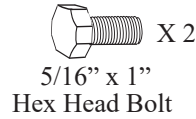
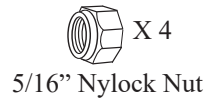

Step 11: Assembling the Bed Face (Continued)

As illustrated below, insert the Allen Head Bolt through bolt hole # 1 and tighten it down securely using a Nylock Nut. Now insert a 5/16" x 1" Hex Head bolt through hole # 3 and thread the Nylock nut ONLY UNTIL THE NUT IS FLUSH WITH THE END OF THE BOLT. Bolt hole #2 will be used in a later step and is left open for now.

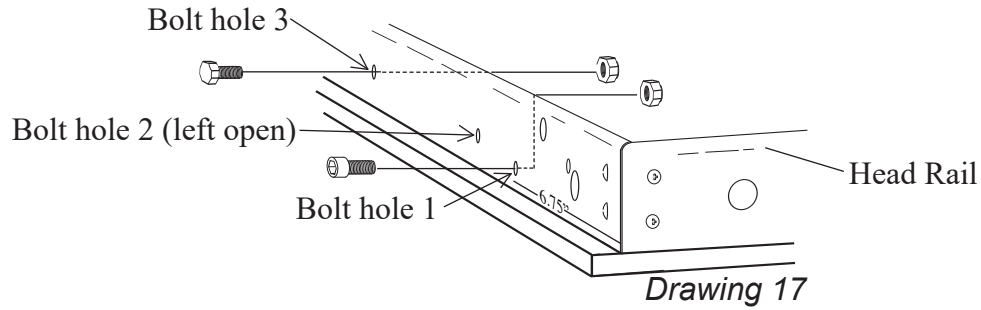

Hardware needed for next step from hardware pack #4

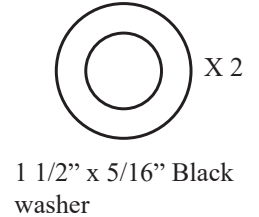
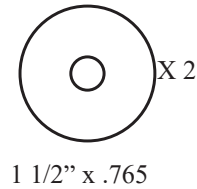
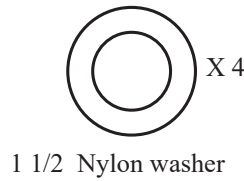
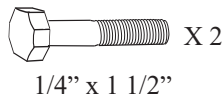

Step 12: Installing the Legs

Attach the Leg Assembly to the FOOT RAIL side of the frame as illustrated below. Use 1 Nylon washers on the out side of the frame for proper spacing.

Position the Cross Bar between the Legs. Place the Star washer on one of the 1/4" X 1 1/2" Hex Head bolts.

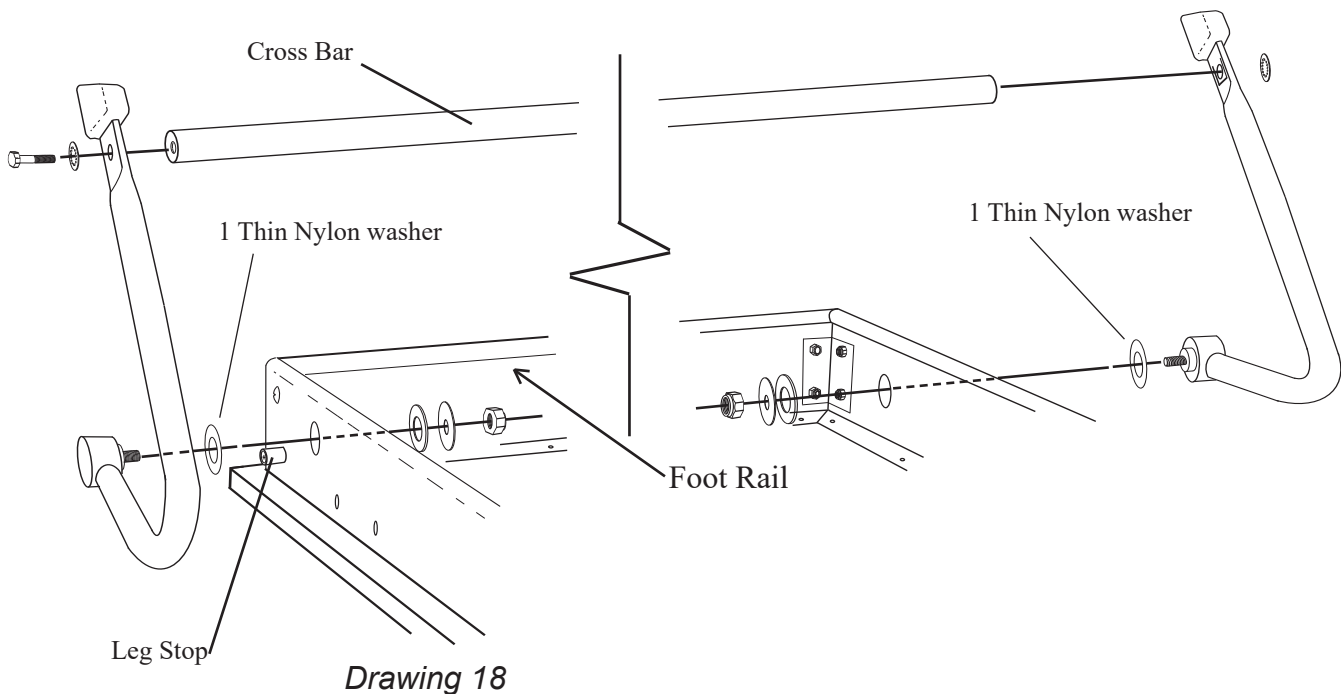

WARNING: There is tremendous force involved in the next step, do not place hands between the front of the side boards and the tension arms as you set the mechanism.

Step 13: Loading the Lift Mechanism

Brace one foot against the front edge of the Side Board and using the 14.5" black metal tubing provided in Mechanism Box, lever the Lift Mechanism's Lift Arm out and down until you can secure the Arm Lock onto the Welded Collar. (See Drawing 19) BE SURE THAT THE LOCK IS SECURED AGAINST THE COLLAR BEFORE RELEASING THE TENSION ON THE LIFT MECHANISM.

Helpful hint: As you start to draw the Lift Arm down with one hand, use the other hand to position the Arm Lock on top of the Welded Collar. Now as the Lift Arm continues to be pulled down with both hands, the Arm Lock will naturally drop into place around the Welded Collar as illustrated.

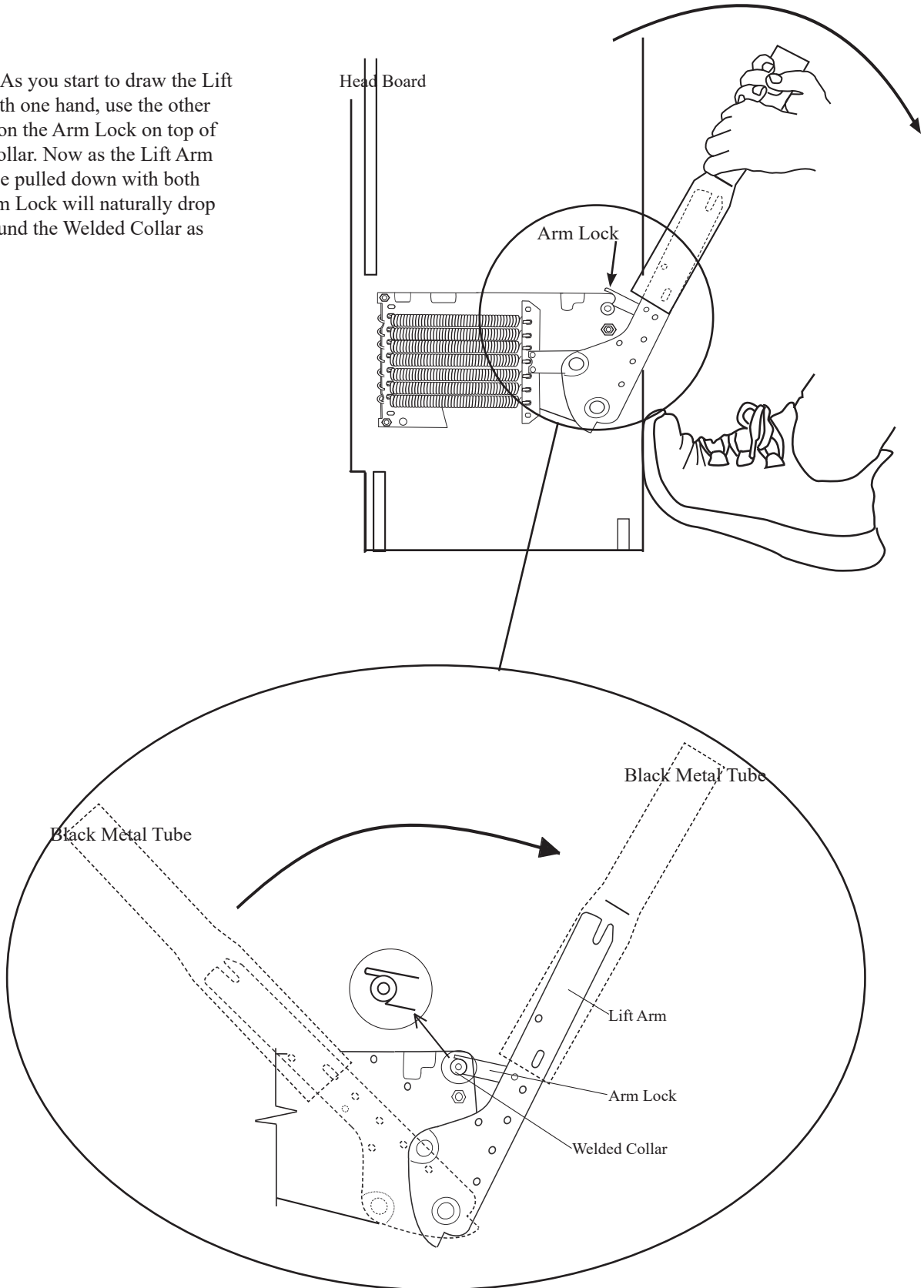

Step 14: Installing the Spring Cover

Slip the Mechanism Cover (from mechanism box) over the Mechanism so that the tabs on the cover fit into the notches provided. Line up the top hole with the barrel support and anchor in place using the 3/16" x 1 1/4" wood screw provided

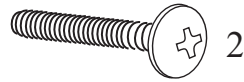

3/16"x 1 1/4" Black Wood Screw

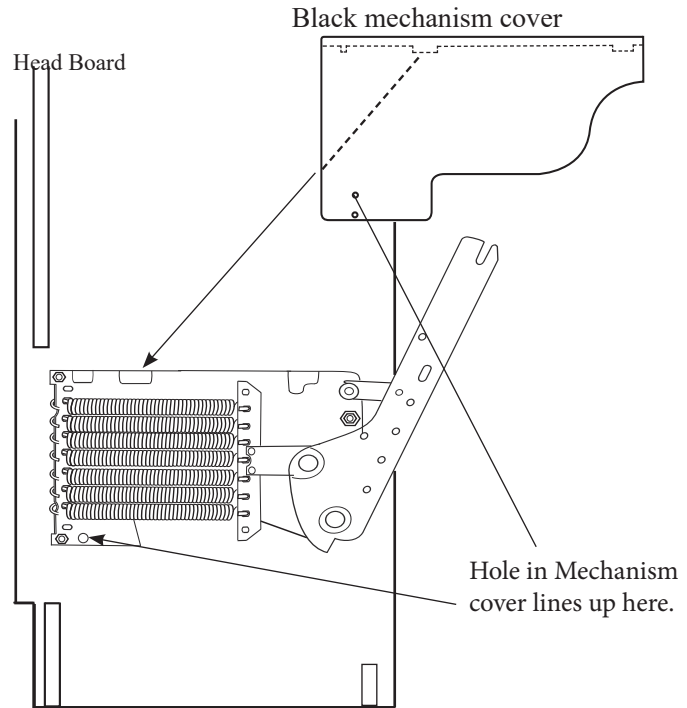

Drawing 20

Step 15: Installing the Bed Face on the Lift Mechanism

IMPORTANT! As instructed in a previous step, Bolt #3 should be loose enough to slip into the notch at the end of the Lift Arm See illustration below.

Two person Step: Stand the Bed Face unit up on its Head Rail. Now with you and your assistant on either side of the Bed Face unit lift until the # 3 bolt on the Side Rail is a few inches above the slotted end of the Lift Arm on both sides. Gently lower the Bed face unit between the Lift Arms and seat the # 3 bolt into the slot at the end of the Lift Arms. Now start pulling the bed face unit down and away from the Bed Cabinet the Allen Head bolt will naturally seat into the notch at the lower end of the Lift Arms. Lower the bed unit down and extend the Legs so that they are on the floor. Someone will need to hold the bed unit down as it will want to rise.

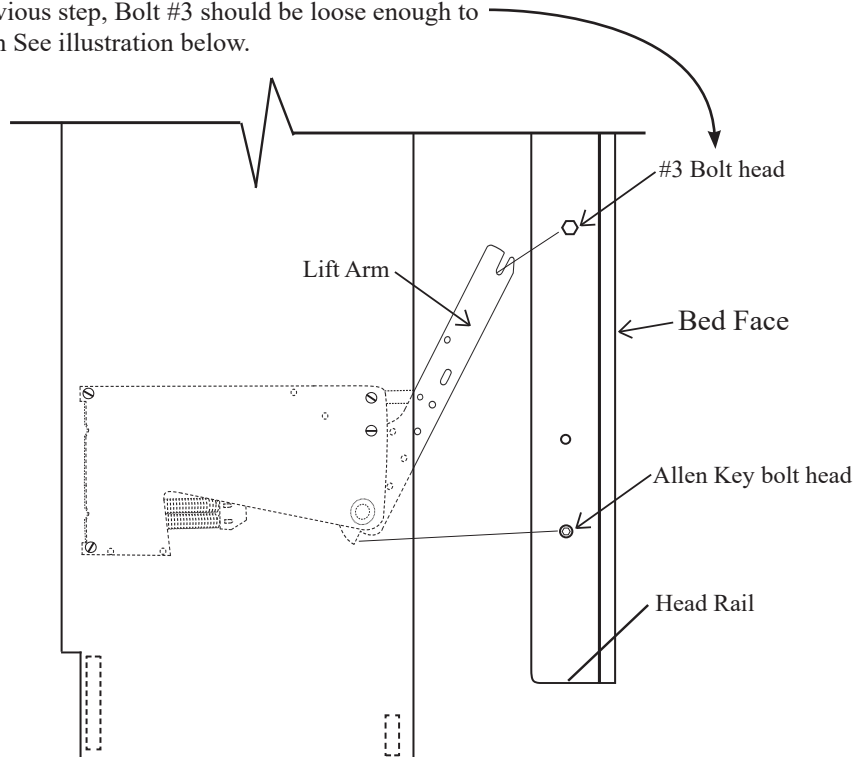

Drawing 21

Hardware needed for next step from hardware pack #2

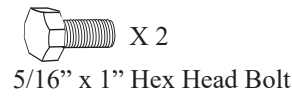
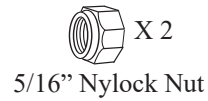

Warning very important step!

Step 16: Installing the Bed Face on the Lift Mechanism (Continued)

Insert a 5/16" x 1" Hex Head bolt through hole #2 and tighten a 5/16" Nylock nut onto the bolt. Now tighten the nut and bolt in hole #3.

Repeat step on the other side of the bed unit.

WARNING! Failure to insert and tighten all the bolts in step 16 could result in **severe personal injury** or damage to the lift mechanism. Lift mechanism damage caused by missing or loose hardware is not covered by warranty.

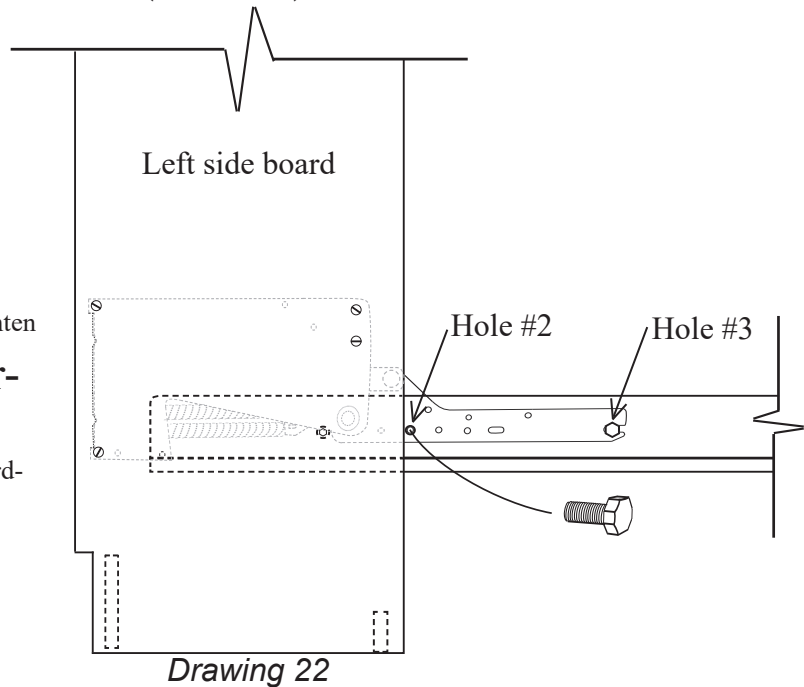

Step 17: Adjusting the Fit of the Bed Face

When the bed is closed, check to see if the gap on either side is the same. If the gap appears to be equal, skip this step. If the gaps are not right, meaning that the bed's face panel is too close to one sideboard, or, even touching it at the top while the other side has a large gap it will need to be adjusted. The procedure will require the bottom of the bed to be moved slightly to the left of right depending on which side has the smaller gap. If the Bed Face is too close on the top right (see illustration) for instance, the right side (bottom) will be to be moved to the left slightly. Have one person push the bed at the bottom with their feet while the second person pulls at the opposite bottom side.

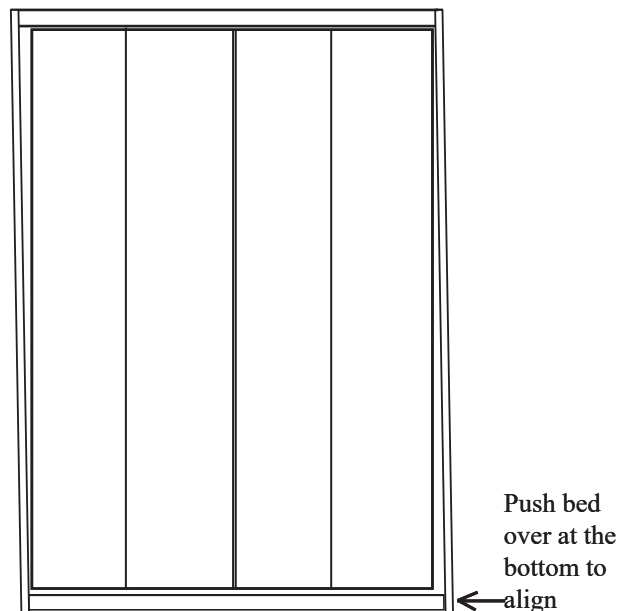

Step 18: Installing Handles (supplied locally)

Measure and drill holes in the bed face where Handles are desired.
Note Handles should be positioned more toward the top of the Bed Face for easier opening (Queen and King approx. 5 ft. from floor).

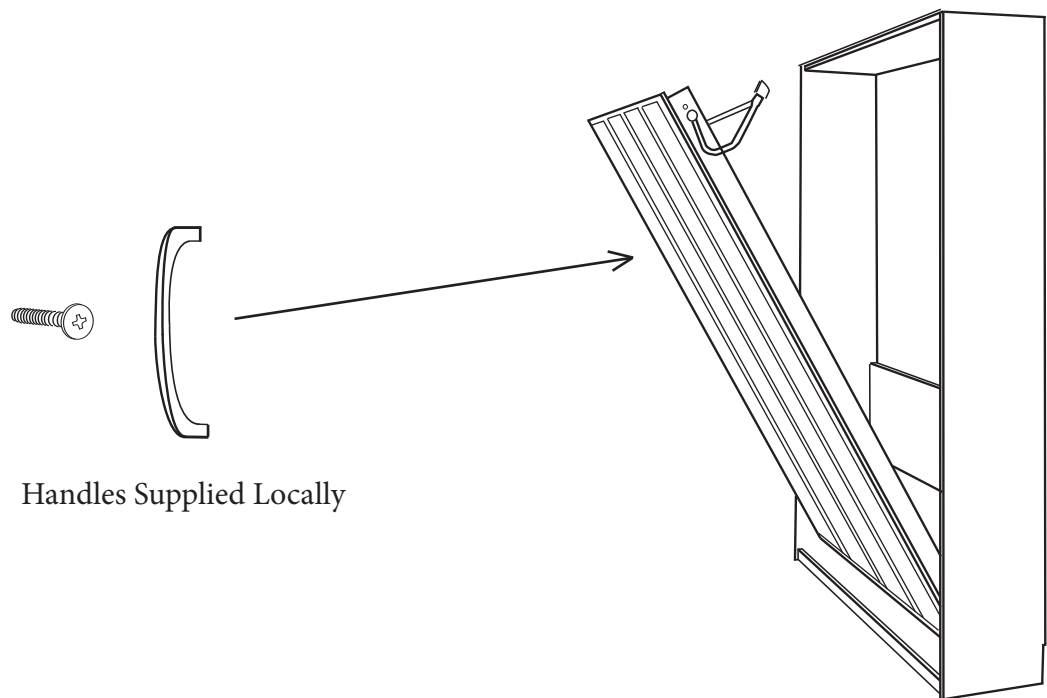

Handles Supplied Locally

Drawing 24

