

UN-INSTALLING WILDING WALLBEDS

Step 1: Disconnect Side Cabinets from the Wallbed.

Step 2: Remove Crown Mold from the Wallbed.

Step 3: Remove Base mold from the Wallbed.

*Note: not all style beds have Base molding, and not all Base molding is removable at this point. To see if your bed has removable base mold, open the bed to approximately 45 degree angle and look immediately behind the Base mould for three screws in small "L" brackets.

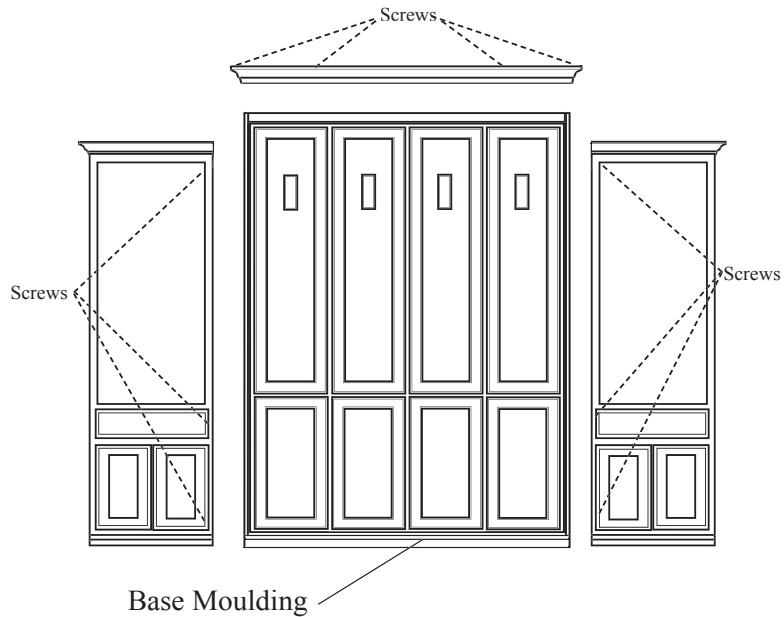

Step 4: Remove Mattress

Step 5: Remove the screws from the top/back of the Wallbed that attach the bed to the wall. With HELP lay the bed face down on the floor.

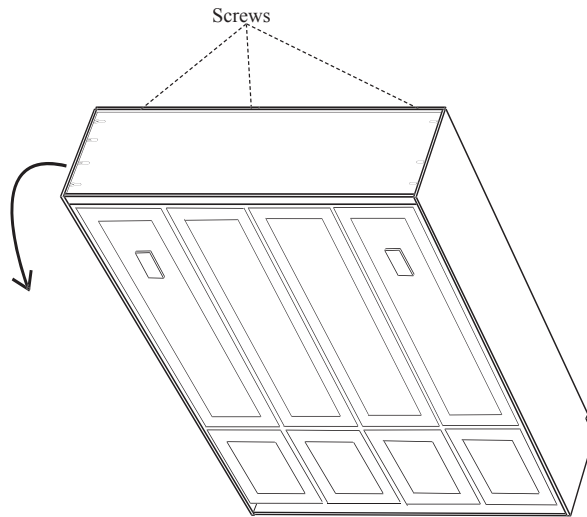

Step 6: Remove Headboard, Bridge board and Stretcher.

*Note: Not all Beds have Stretchers

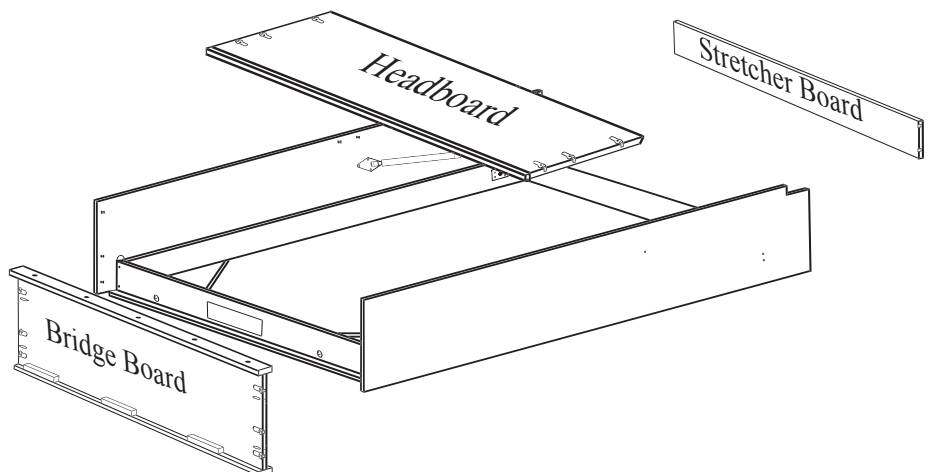

Step 7: Spread out the Side Board tops slightly so the Bed Box has clearance to pass through the Bed Stops on the Side Boards.

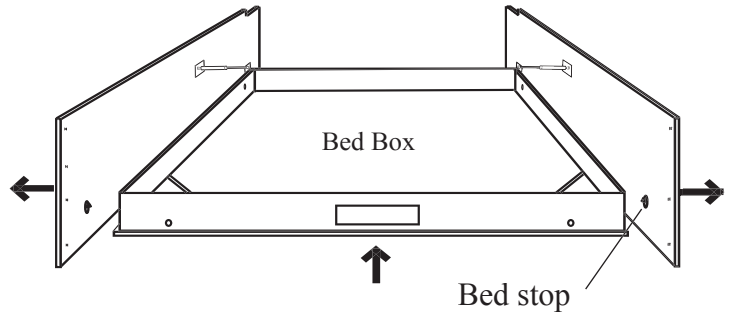

Releasing The Gas Pistons

Requires 2 people

Step 8: While slightly lifting the end of the Bed Box up between 2 and 6 inches (the Side Boards must remain flat on the floor) pry the retaining spring out from the piston head with a small regular screwdriver. You will need to move the Bed Box up and down slightly to find the position the piston will release.

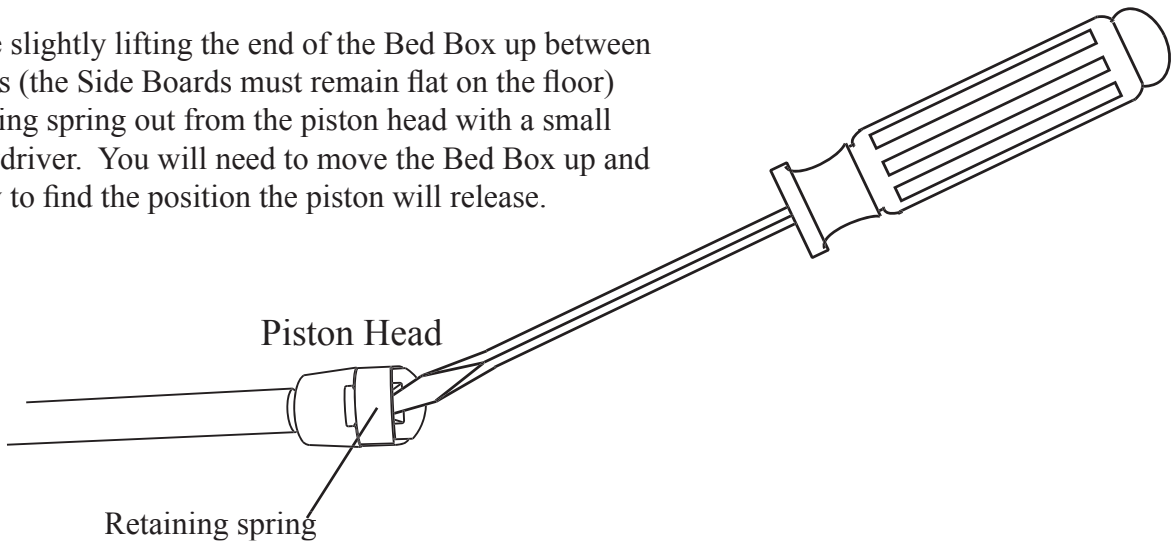

Step 9: With a small regular screw driver, remove the E-clips from pivot posts and slide the Side Board away from the Bed Box.

