

WILDING WALLBEDS INSTALLATION INSTRUCTION STORAGE HEAD BOARD

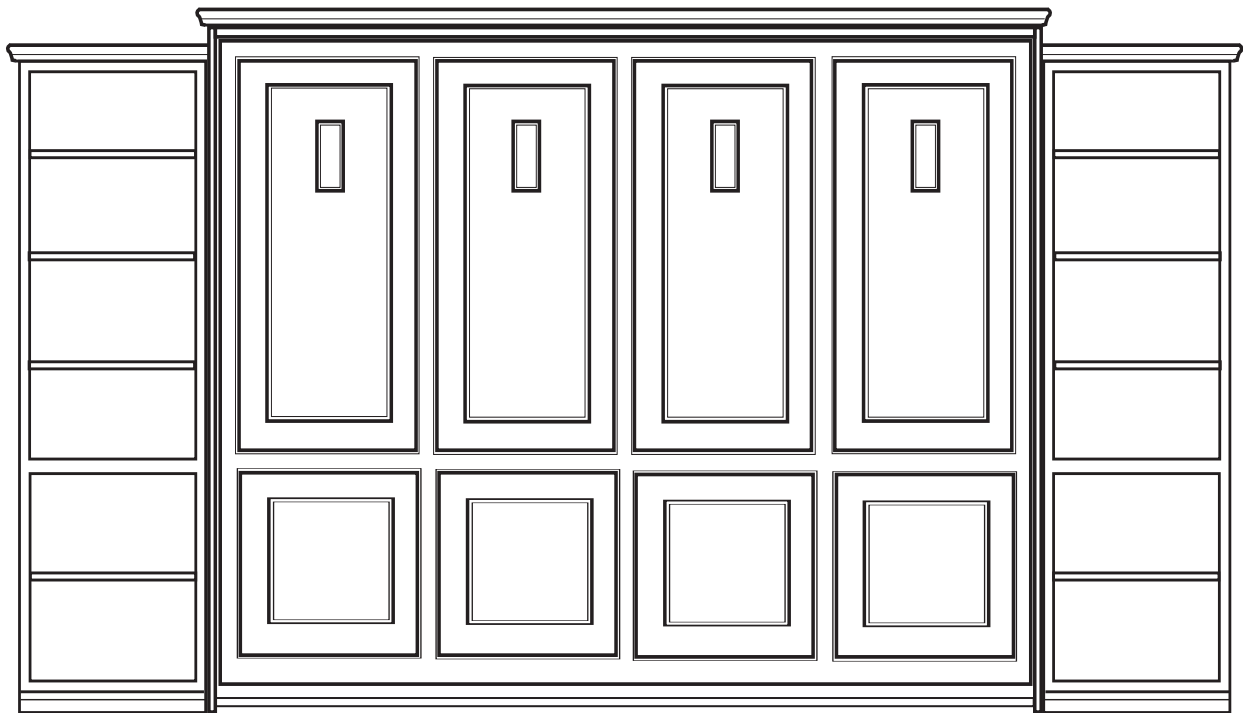



Booklet 15



WARNING! ALL MURPHY/WALLBED SYSTEMS CONTAIN POWERFUL LIFTING COMPONENTS. FAILURE TO USE AND FOLLOW THESE INSTRUCTIONS DURING THE INSTALLATION PROCESS COULD RESULT IN SEVERE PERSONAL INJURY TO USER OR DAMAGE TO PRODUCT. PLEASE CONTACT CUSTOMER SERVICE AT 866-725-6401 FOR ANY QUESTIONS.

Revision 9/12 BK15

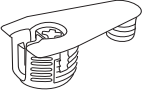
Hardware Supplied

QTY	SIZE	
3	3 1/2" Grabber	
10	1 1/2" Grabber	
4	1 1/4" Grabber	
3	Cam Fitting (extras)	
3	Connecting Bolt (extras)	

Tools Needed

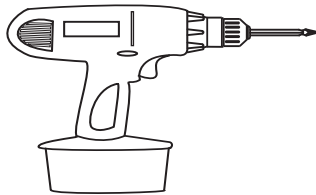

Cordless Screw Driver
or Power Drill with Phillips bit



Pliers

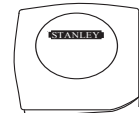

Tape Measure

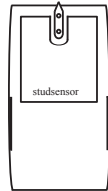

Stud Sensor



Small Regular Screw Driver



Phillips Screw Driver



1/4" wood drill bit

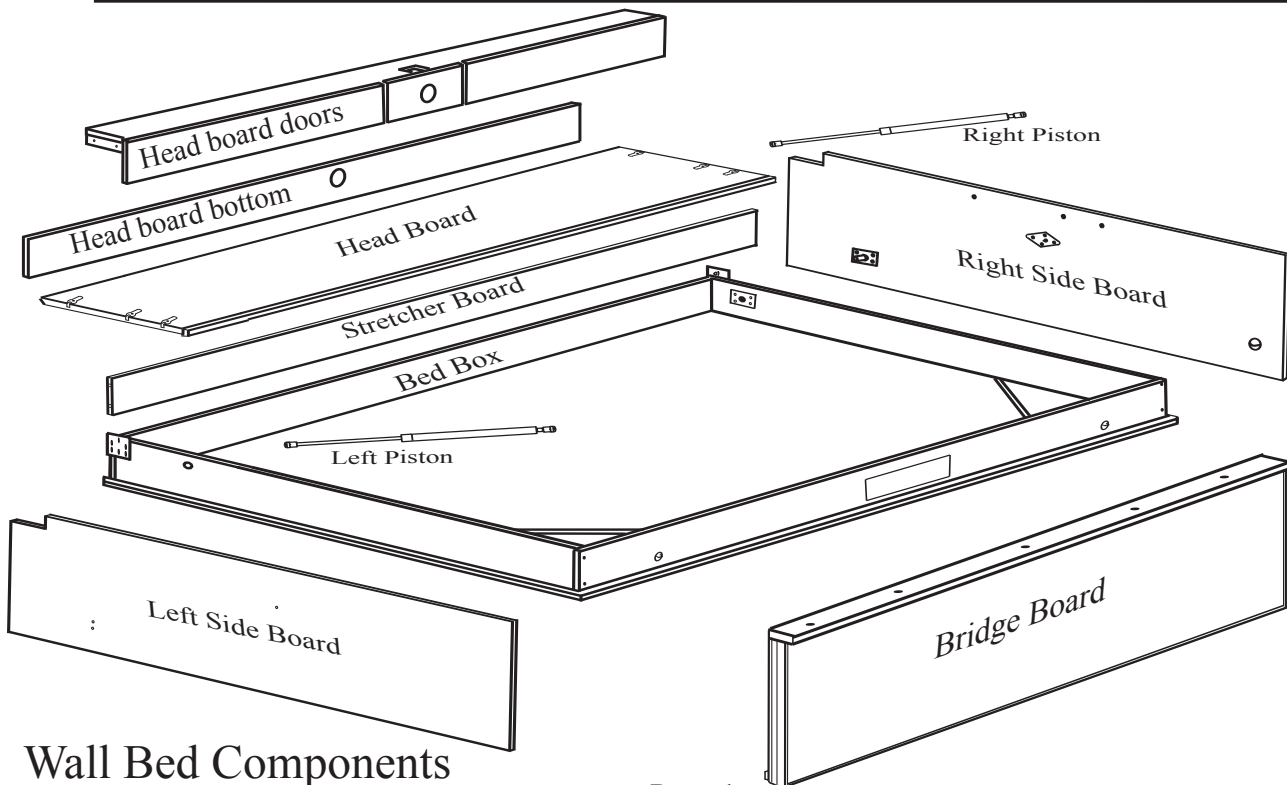

Wall Bed Components

Step 1: Position Bed Box and Right and Left Side Boards in your room with the bottom of the bed closest to the wall the bed is to be installed against.

CAUTION: If your floor is hardwood, tile, or any other hard type flooring, place a blanket down first to protect the bed front from scratches.

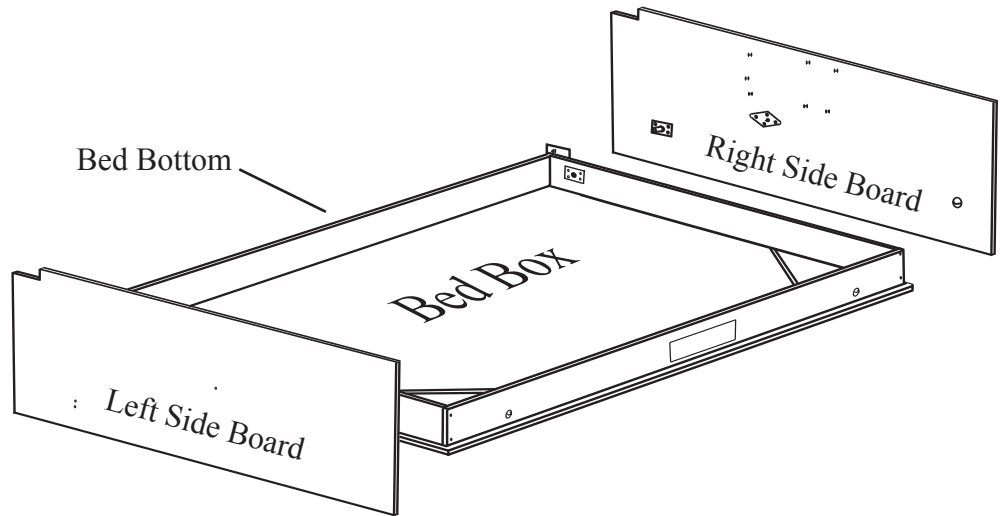

Side Board Illustration

For ease of assembly, familiarize yourself with side board parts below.

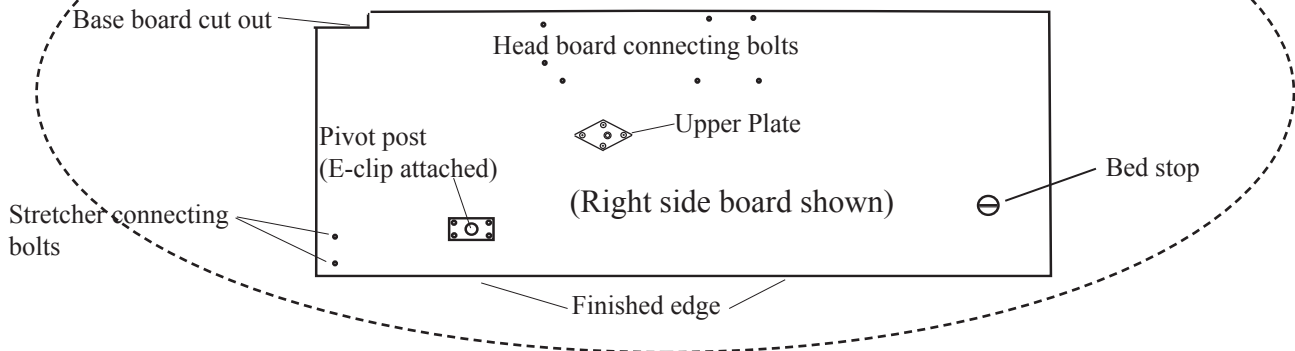

Step 2: With a pair of pliers, or a small regular screw driver, remove the E-clips from pivot posts on the Side Boards. Leave the white nylon spacers in place on the Pivot Posts.

Step 3: Slide Side Board Pivot Posts through the Pivot Holes in the bed box as shown. Then replace the E-clips by snapping them back onto the Pivot Posts in groove provided.

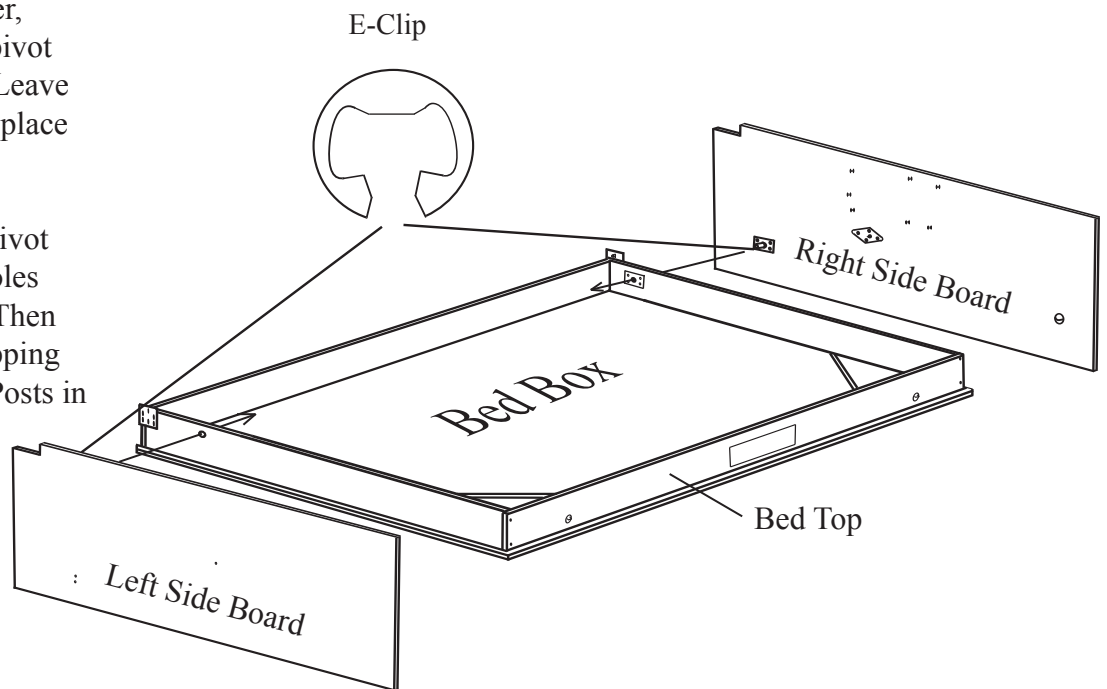

Lift Piston Illustration

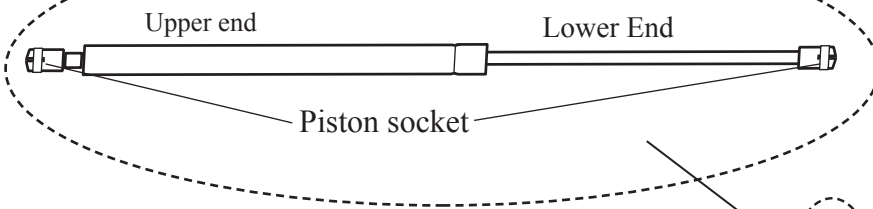

Step 4: Attach the lower end of the LIFT PISTON (skinnier end) onto the LOWER ANCHOR PLATE on both sides of the bed box by positioning the socket end of the piston directly over the anchor ball on the anchor plates and pushing them on. The piston socket should snap into place over the anchor ball.

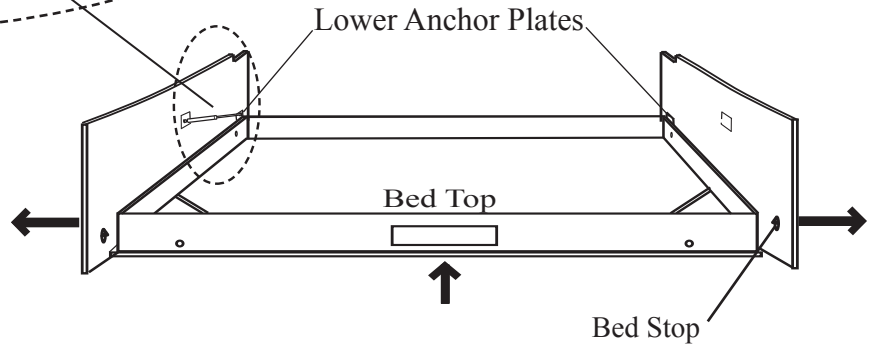

Step 5: Spread out the Side Board tops so the Bed Box has clearance to pass through the bed stops on the Side Boards.

Step 6: This step will require two people. One person will need to kneel down in front of the Bed Box and lift it up about 5 to 7 inches. The second person will position the upper socket end of the LIFT PISTON directly over the anchor ball on the upper anchor plate and snap it into place. The first person may need to raise and lower the Bed Box slightly to allow the piston

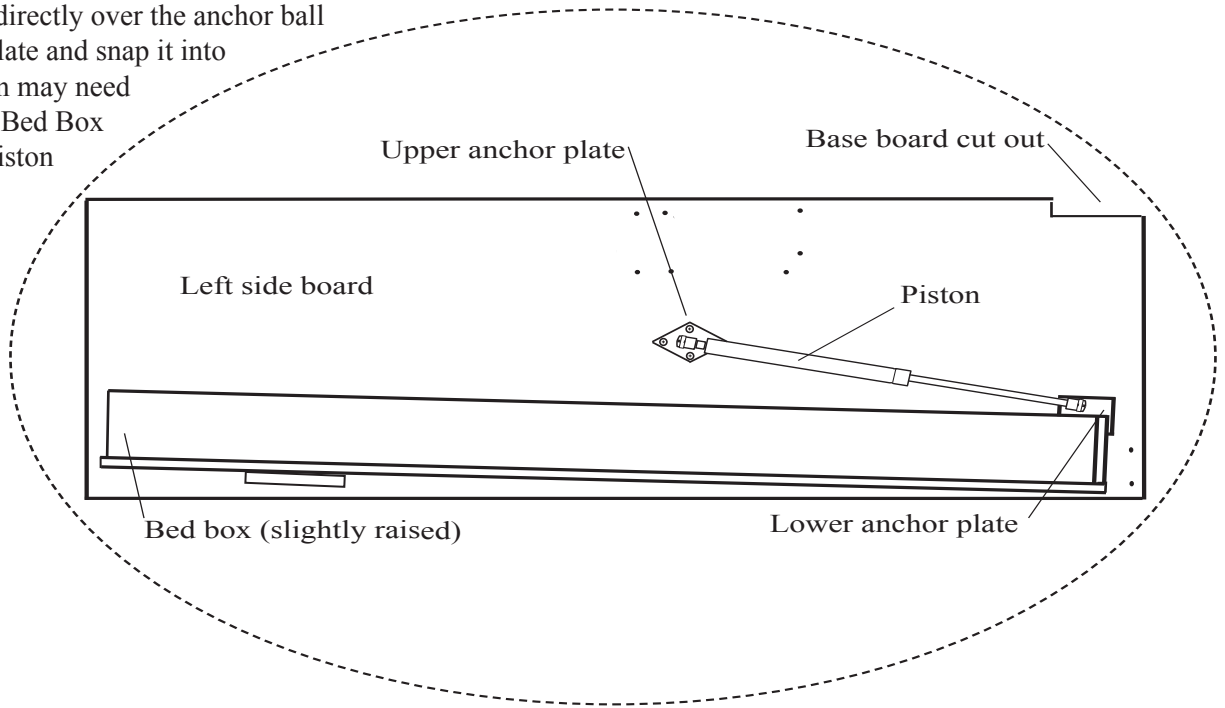

Step 7: With the bed still laying face down on the floor the Headboard can be installed. **HAVE SOMEONE HELP WITH THIS STEP.** Slide the Headboard between the Side Boards and under the Connecting Bolts then slide the Cam Fittings into the Connecting Bolts and tighten the Cam fittings by turning them clockwise. Do this procedure by hand **DO NOT USE A POWER SCREW DRIVER.**

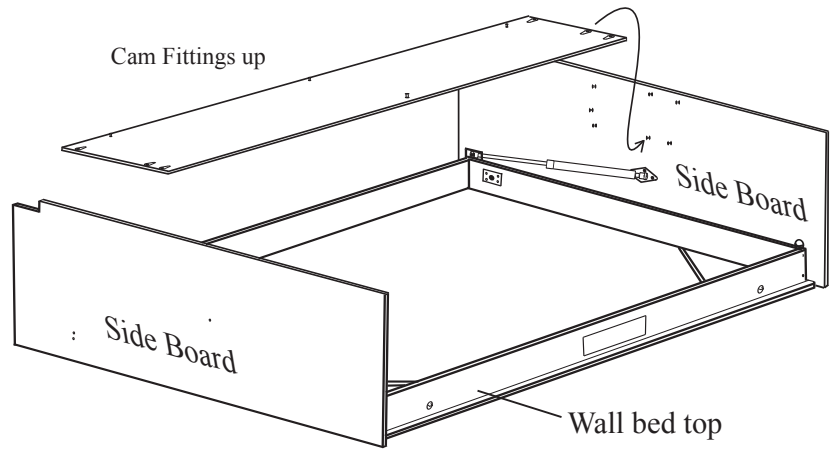

Step 8: Install the Storage Headboard bottom as illustrated. Make sure to orient the piece as shown with the Cam Fittings down.

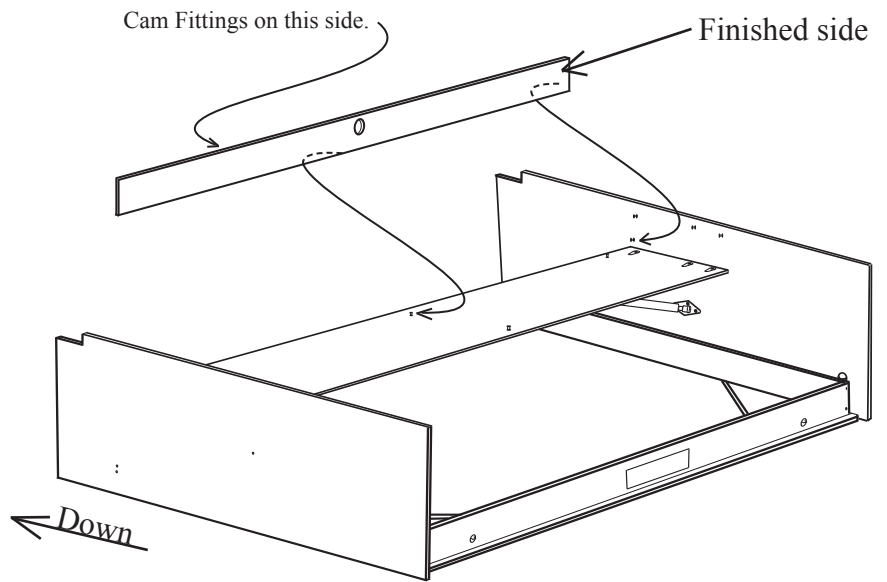

Step 9: Install the hinged storage door unit as illustrated.

Helpful hint: You may need to lift the center section to get the unit positioned correctly

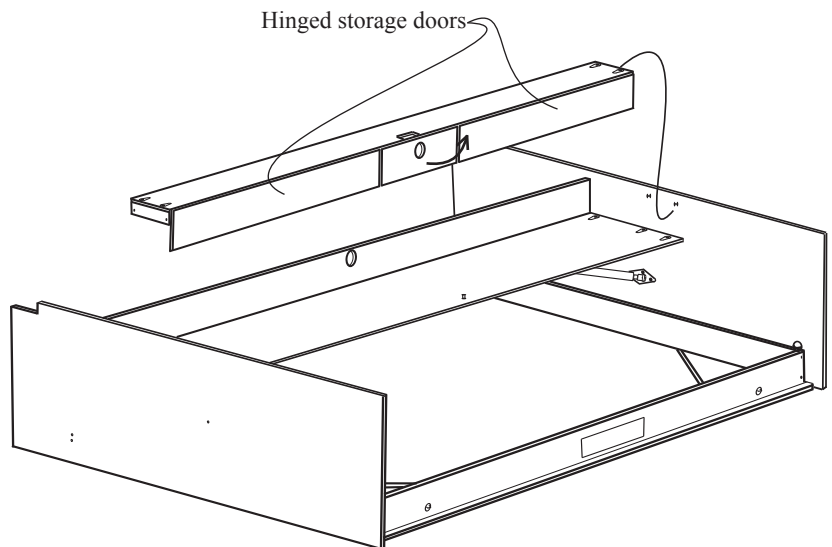

Step 10: Once the Head Board is attached to the Side Boards place the Brass Bed Bumpers onto the Bed Rail on both sides of the bed box.

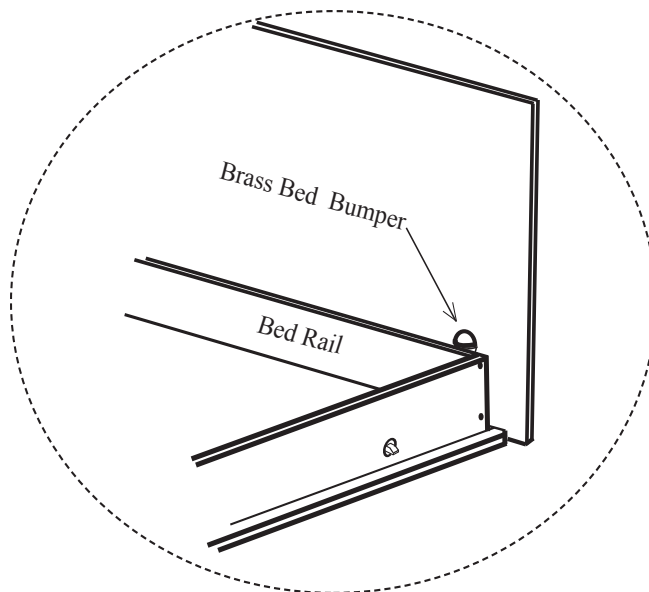

Step 11: Locate the Stretcher Board and slide it between the Side Boards at the bottom of the Wallbed. Insert the Connecting Bolts into the Cam fittings and tighten them by turning the cam clockwise. Do this procedure by hand DO NOT USE A POWER SCREW DRIVER.

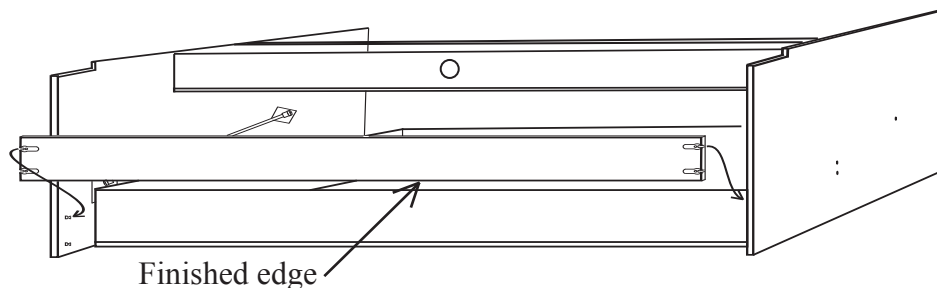

IMPORTANT NOTE! Position the Stretcher so the 3/4" finished edge is DOWN toward your floor.

Step 12: Have someone help lift the Wall Bed into the standing position. Leave it about 2 feet from the wall the bed is to be installed against so there will be room to work behind the bed.

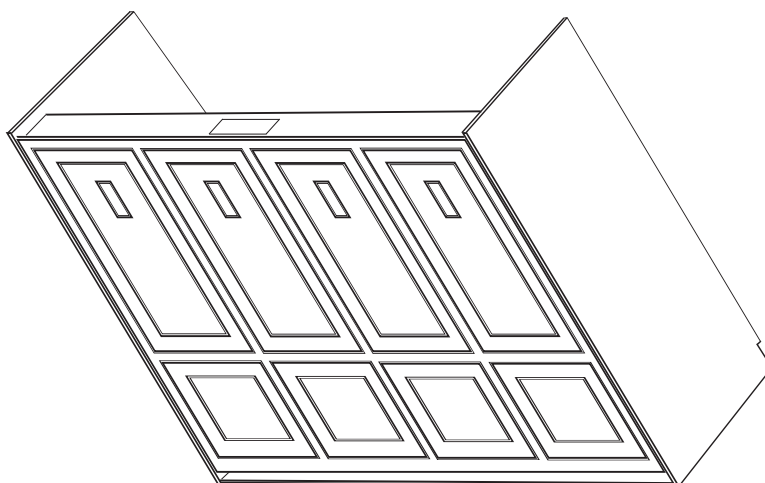

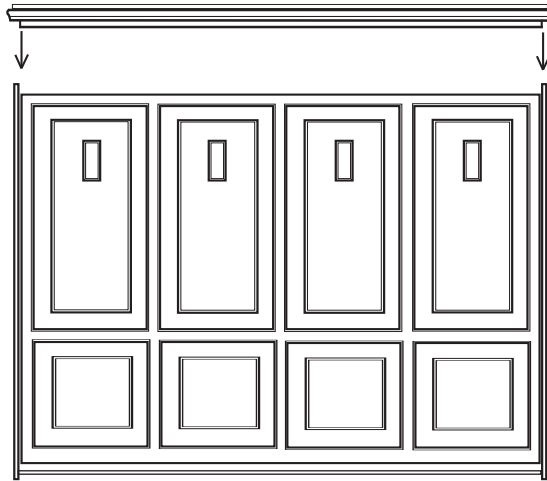

Step 13: Place the Bridge Board on top of the Wall Bed and position it so the front of the Bridge is flush with the front of the Side Boards.

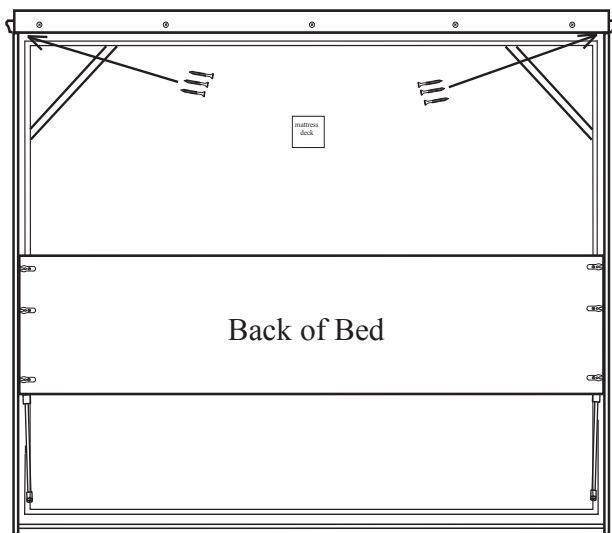

Step 14: From the back of the Wall Bed attach the Bridge to the Side Boards using three (on each side) 1 1/2" screws. Place the screws through the holes provided in the corner blocks on the Bridge Board and drive them into the Side Boards.

Step 15: Once the bed is standing up, slide it back and position it against the wall where it is to be installed. Check the gap between the Side Boards and the Bed Box on both sides. The gap at this point will probably need to be adjusted. You can adjust the gap by pushing the bed to one side or the other at the top of the bed. Pushing it will even the gap from top to bottom on each side. At this point don't worry if one side has a larger gap than the other as long as each sides gap is about the same from top to bottom on each side.

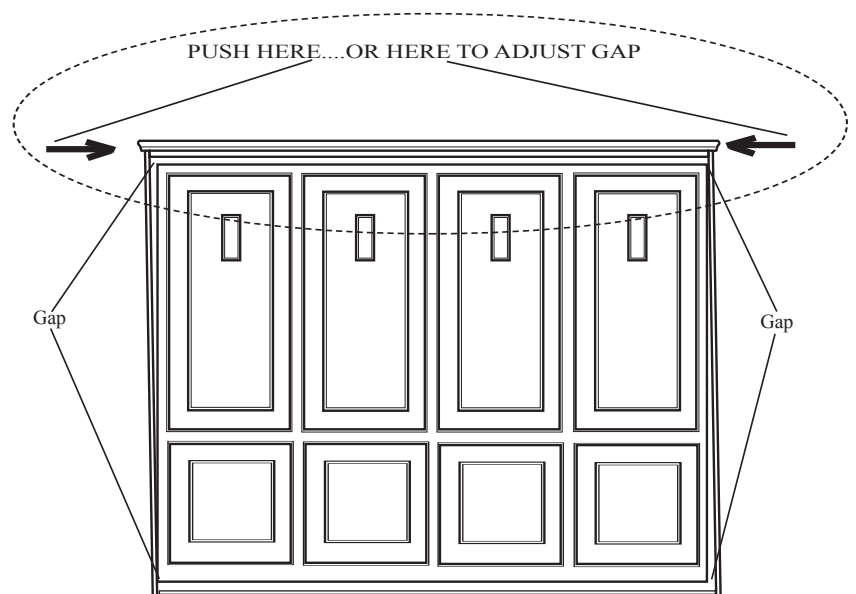

WARNING: THE NEXT 2 STEPS MAY REQUIRE PROFESSIONAL HELP.

FAILURE TO PROPERLY ANCHOR WALLBED TO YOUR WALL COULD CAUSE THE BED TO FALL AND SEVERE PERSONAL INJURY COULD RESULT. CALL TECHNICAL SUPPORT AT 866-877-7803 IF YOU HAVE ANY QUESTIONS.

Step 16: Locate the studs in your wall with a stud finder, then mark them lightly with a pencil just above the Anchor Board located at the back of the Bridge Board. (see illustration 8) You should find at least 3 studs for anchoring the bed to the wall. IF YOUR WALLS ARE NOT TRADITIONAL WOOD FRAMING, YOU MAY NEED TO HIRE A HANDY MAN OR CONTRACTOR TO HELP IN ANCHORING THE BED SECURELY TO YOUR WALL.

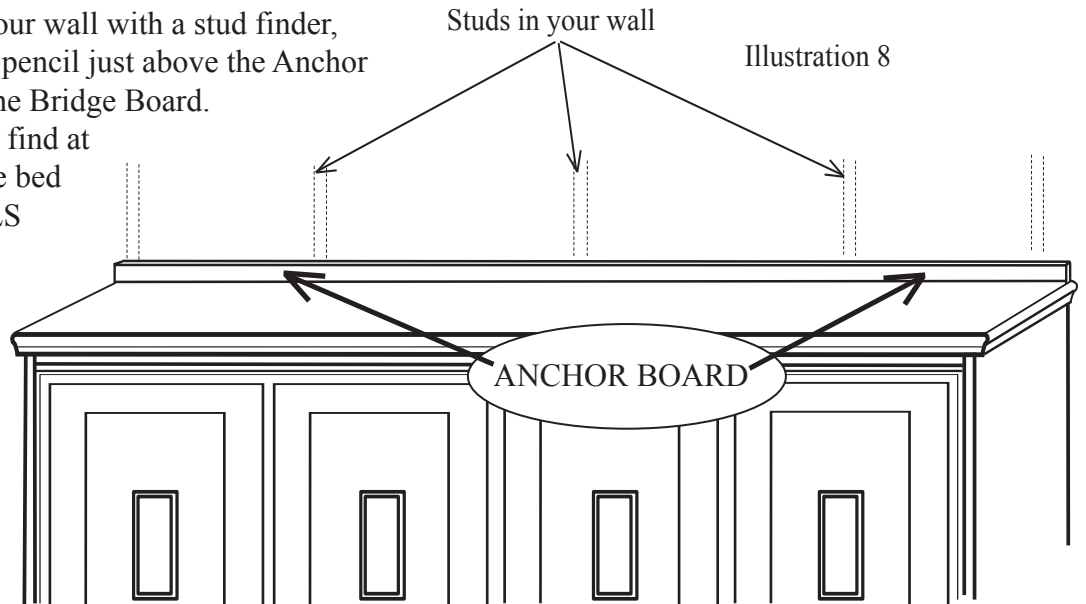

Step 17: Using a 1/4" drill bit pre-drill holes through the Anchor Board that correspond with the 3 studs you will use to anchor your bed to the wall. Now, using three, 3 1/2" screws (illustration 8-A) anchor the Wall Bed to the wall. IT IS EXTREMELY IMPORTANT THAT THE BED IS ANCHORED SECURELY TO THE WALL.

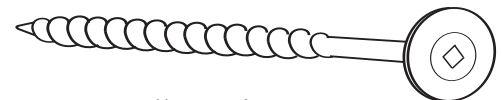
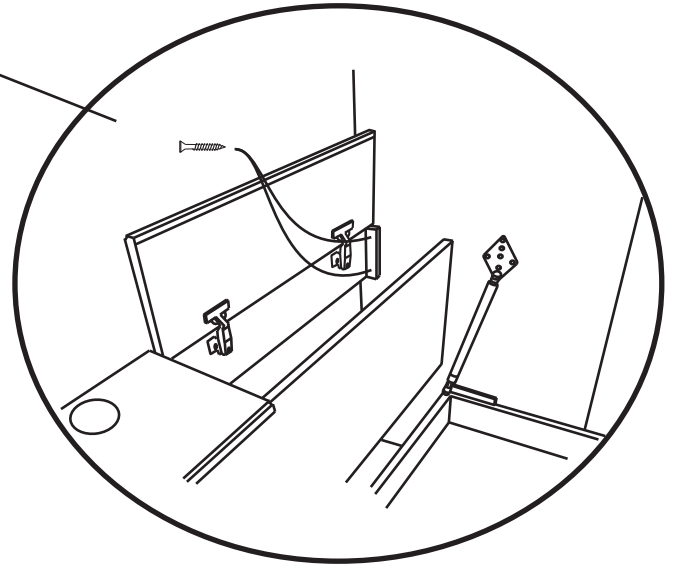
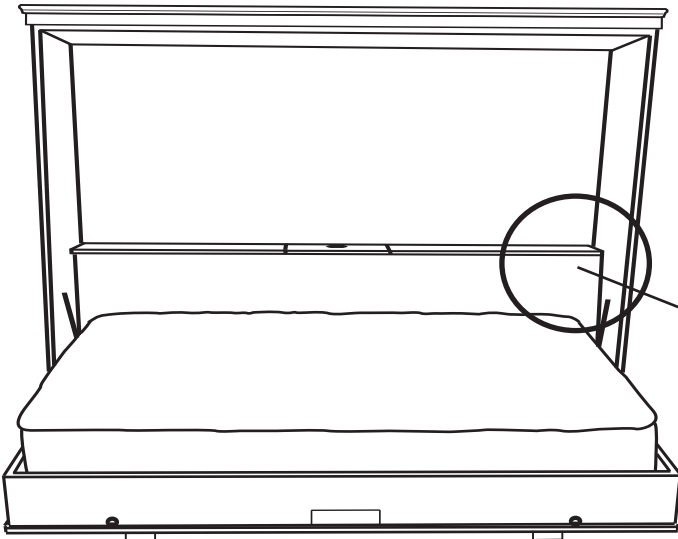

Illustration 8-A

Step 18: With bed open and the mattress in the bed box (to hold down the bed) open the storage head board on both sides. Insert two 1 1/4" gold screws in either side of the lid support through holes provided as shown.

Important: Failure to insert screws in lid support will cause damage to storage head board unit and will not be covered by warranty.



SIDE CABINETS

NOTE: It is recommended to attach the side cabinets to the bed so they fit tight to the bed and are secured properly.

NOTE: Side cabinets contain their own hardware.

Step 19: Anchor the Side Cabinet to the Bed by first pre-drilling two 3/16" holes at the inside edge of the side cabinet. Position the holes close to the front edge of the side cabinet just behind the Face Frame. One hole should be near the top, the second about 15" from the bottom of the cabinet. (illustration 9)

Illustration 9

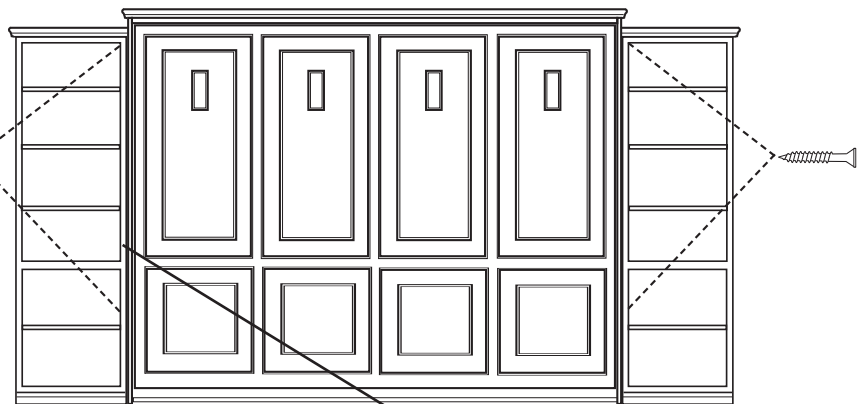

Step 20: Use three 1 1/4" Gold Screws through pre-drilled holes to anchor Side Cabinets to the Bed's Side Boards. (See illustration 9)

Face frame (front edge)

Step 21: Insert Gold Shelf Supports at desired location in Side Cabinets then place adjustable shelves.