

WILDING WALLBEDS INSTALLATION INSTRUCTION

INSTRUCTION BOOKLET #44

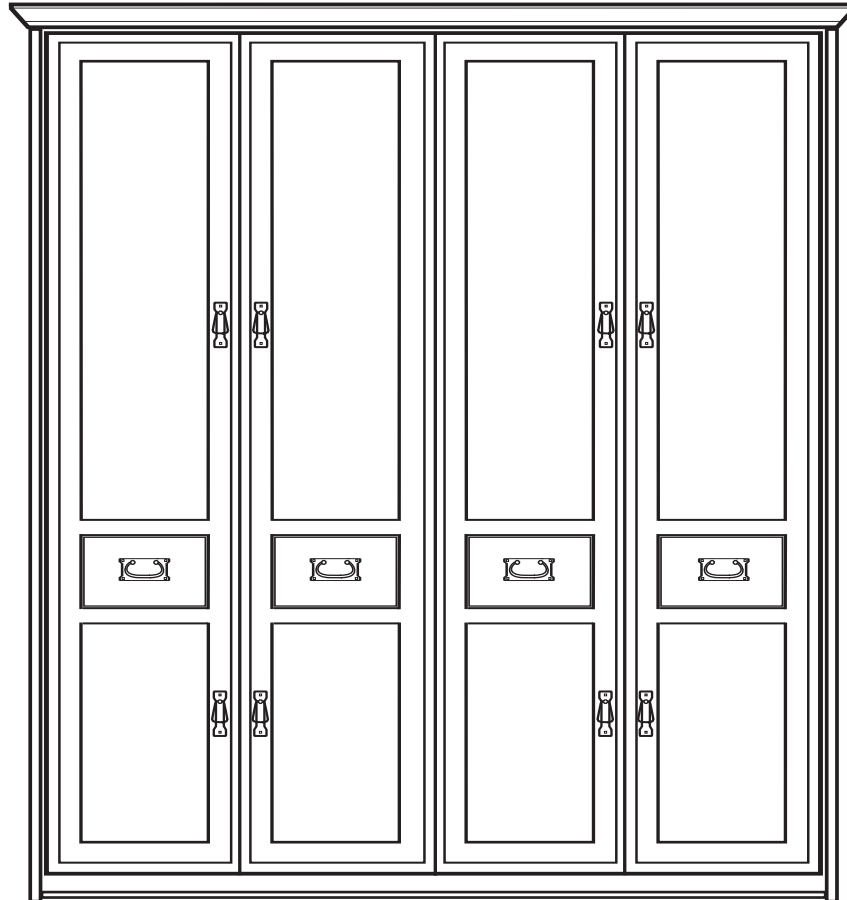

For Wallbed models:
Mission

KING SIZE
WITH STORAGE
HEADBOARD

WARNING! ALL MURPY/WALLBED SYSTEMS CONTAIN STORED ENERGY. FAILURE TO USE AND FOLLOW THESE INSTRUCTIONS DURING THE INSTALLATION PROCESS COULD RESULT IN SEVERE PERSONAL INJURY TO USER OR DAMAGE TO PRODUCT. PLEASE CONTACT CUSTOMER SERVICE AT 866-725-6401 FOR ANY QUESTIONS.

Revision 10/11 BK37

Tools Needed

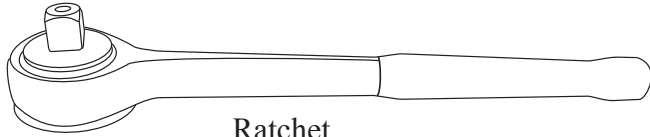

Ratchet

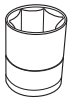

1/2" Socket



3/8" Socket



7/16" Socket

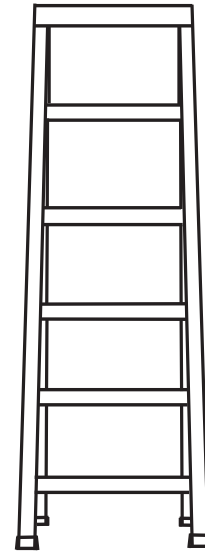

6 foot ladder

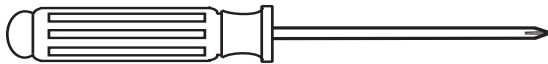

Phillips screwdriver



Crescent wrench

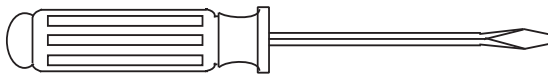

Large regular screwdriver

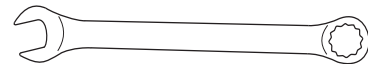

1/2" open end wrench



Small regular screwdriver

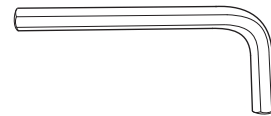

1/4" Allen wrench

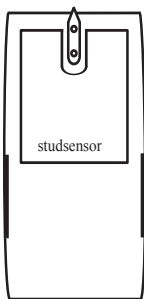

Stud finder

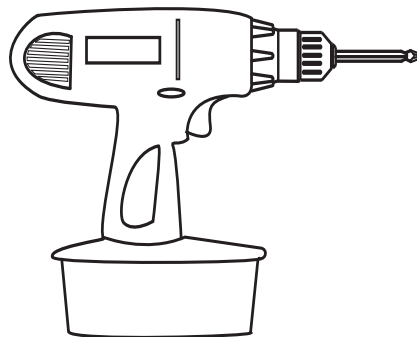



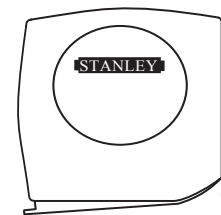





Cordless screw driver
with Phillips bit

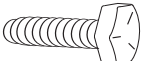

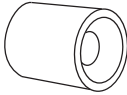

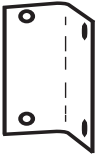
Tape measure

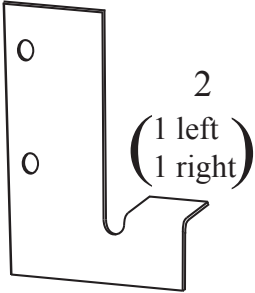
Hardware Page

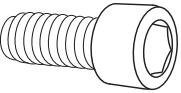
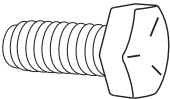
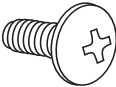
Bag 14

Item	Qty	Item	Qty
	16		2
3/16" Nylock Hexagon Nut		1/4" x 3/4" Hex Head Bolt	
	10		2
3/16" x 1/2" Black Flathead Screw		Leg Stop	
	2		4
3/16" x 1 1/4" Black Flathead Screw		4 hole corner bracket	
	6		2 (1 left 1 right)
5/16" Nylock Hexagon Nut		Spacer Plate	
	2		1
1/4" Star Washer		Small bottle of Loctite	
	2		
5/16" Allen Head Bolt			
	4		
5/16" x 3/4" Hex Head Bolt			
	4		
3/16" x 1/2" Black Truss head screw			

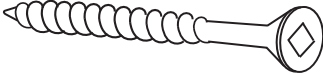
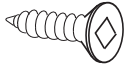

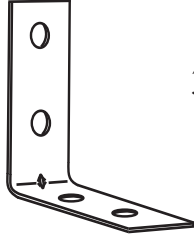
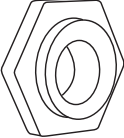
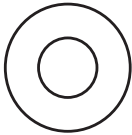
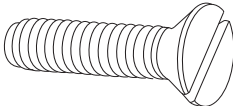
Bag 10

Item	Qty	Item	Qty
	4		6
4 mm x 1/4" Flat Head Screw		2" Flathead Wood Screw	
	6		
3/4" Flat head Screw			
	8		
5/16" Plain Hexagon Nut			
	3		
"L" Bracket			
	2		
3/4" Cam Washer			
	2		
7/8" Washer			
	8		
5/16" x 1 1/4" Flat Head Bolt			

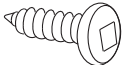
Bag 15

Item	Qty	Item	Qty
	2		190
3/16" Washer		5/8" Pan head Screw	

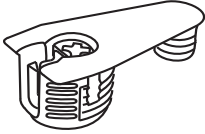
Other Hardware

Item	Qty	Item	Qty
	27		27
Cam Fitting		Connecting Bolts	
Optional Hardware for Side Cabinets 3 per cabinet, found in the top drawer			
	6		
1/4" Gold Flathead Wood Screw			

Step 1: Locate the two Side Boards. If you purchased a King or Queen size bed the Side Boards measure 85" long. Full and Twin size Side boards will measure 80" long. From the square white box locate the two Lift Mechanisms, hardware bags and springs.

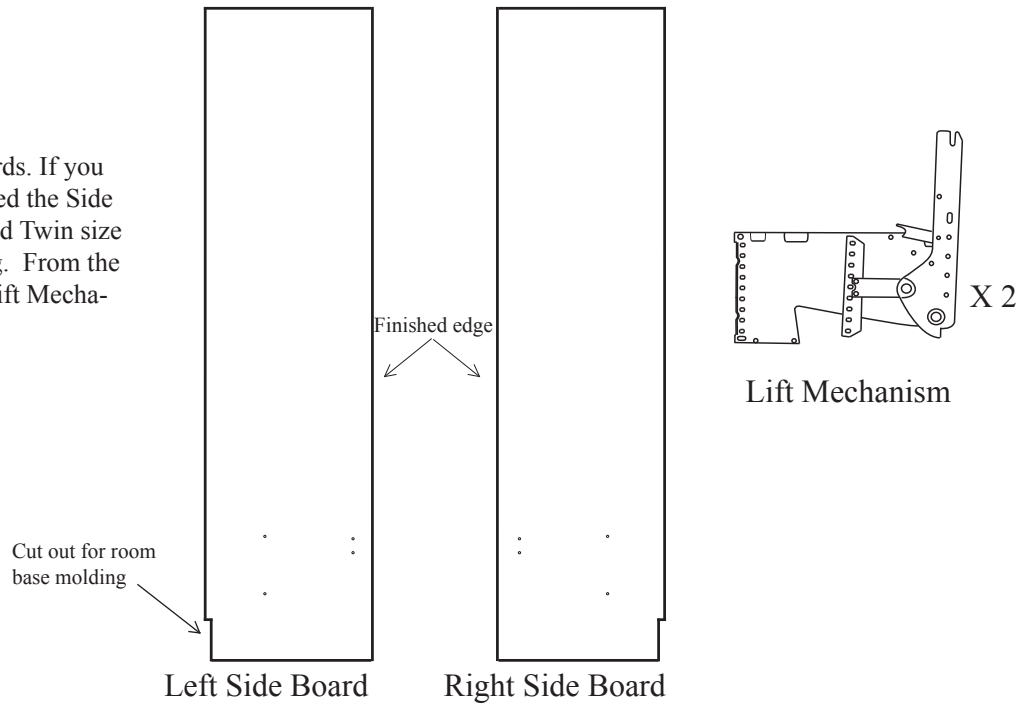

Step 2: Install Springs in the Lift Mechanisms

- The number of springs in the Lift Mechanism required varies with the different weights of mattresses. If you purchased your mattress with your bed from Wilding Wallbeds refer to the chart to the right. This will also be a good reference point for mattresses not purchased with your Wall bed.

Bed Size	Number of Springs
King	9
Queen	8
Full/Double	6
Twin/Single	4

NOTE: After you have completed installing and checking operation of your Wallbed, you may find it necessary to add or remove springs to achieve the correct lift effort of between 5 and 10 pounds.

- Install the first spring in hole #1 for King, #2 for Queen and Full size beds and hole #3 for twin size on both the Mounting Plate and the Tension Arm. Hook one end of the spring under the upturned edge of the Mounting Plate. Lay the spring down and slide it under the matching hole in the Tension Arm. See illustration 1.

HELPFUL HINT: You may find it easier to fit the hook under the Tension Arm if you pry up the Arm Bracket with a wooden wedge or similar device.

- Continue by working up from, hole 2 (Queen and Full size beds) or hole 3, (for twin size), until you have installed the required number of springs.

IMPORTANT! Be sure that holes of the Mounting Plate correspond to the holes in the Tension Arm and use the same number of springs and the same configuration on both Lift Mechanisms

- Repeat Step 2 for Left Lift Mechanism.

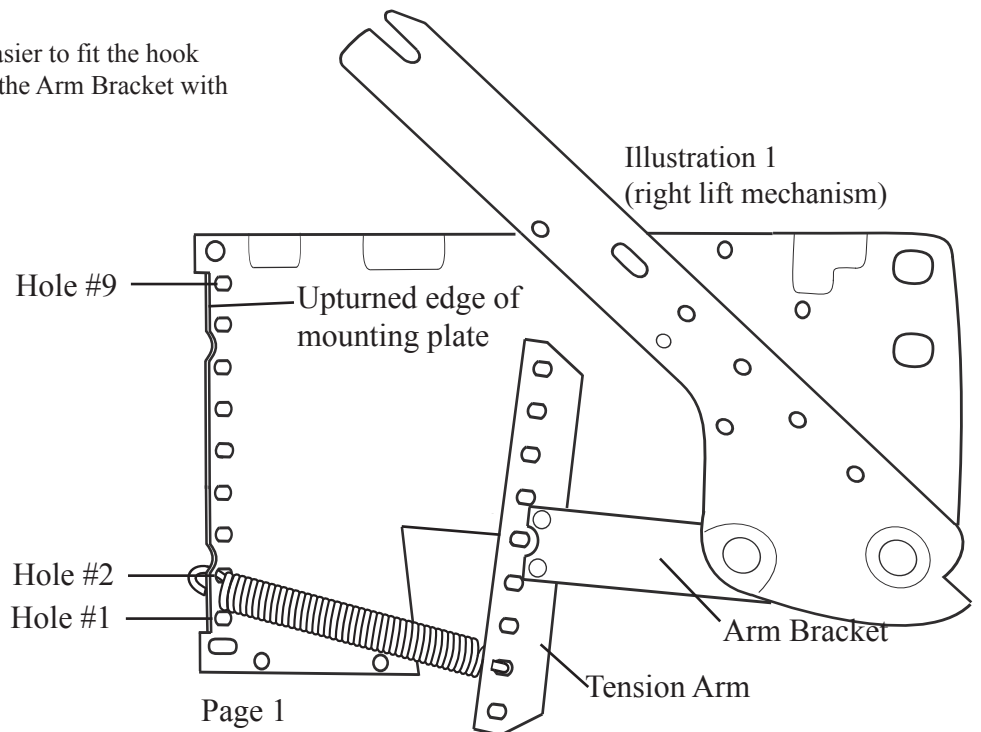

Hardware needed for next 2 steps from Bag #10

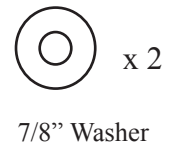
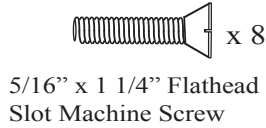

Step 3: Install the Lift Mechanism by inserting a 5/16" x 1 1/4" Flathead Machine Screw through holes "C" and "D" from the outside (countersunk holes) of the Right Side Board. Position the corresponding Right Lift Mechanism holes. Loosely thread on a 5/16" Plain Hex Nut on each. Insert the same type screw through holes "A" and "B". At hole "A" use one of the Hexagon Cam Washers in the slot of the mounting plate so that the LARGER PART OF THE CAM IS DOWN. At hole "B" use a 5/16" x 7/8" washer. Thread a nut on each. Tighten the four nuts evenly, making sure the hexagon cam washer does not rotate while tightening. See illustration 2.

IMPORTANT! Over tightening the nuts will pull the head of the screw too deeply into the Side Board. Tighten only until the head of the screw is flush with the Side Board.

Repeat step 3 with the Left Side Board and Lifting Mechanism.

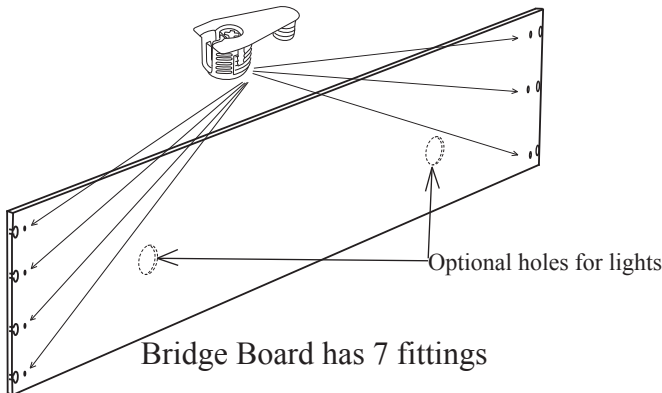
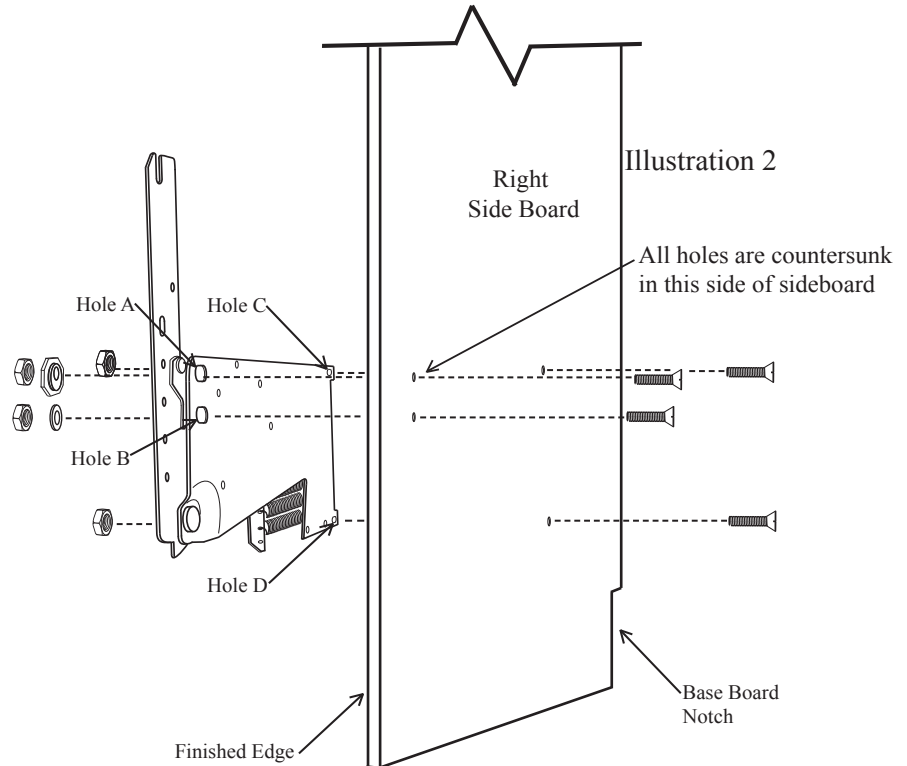

Step 4: Locate the Bridge Board and Insert seven Cam Fittings into the sockets provided. Press the Cam Fittings in so they are tight against the bed part. You may need a rubber mallet to get them properly set.

Helpful hint: The Bridge Board and the Head Board are the same length and could be easily confused. Note the Bridge Board has 7 cam fitting sockets where as the Head Board has either Six or nine.

Step 5: Locate the TWO (2) Stretcher Boards and insert four Cam Fittings into the back of each Stretcher. Press the Cam Fittings in so they are tight against the part. See Illustration 4.

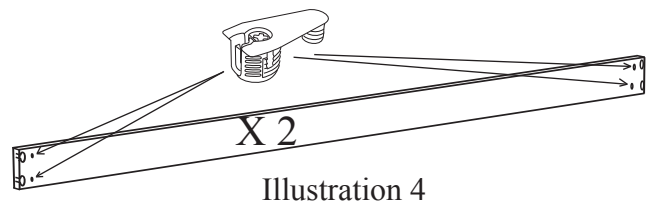

Storage Head board Steps

Storage Head board step A: Locate the Head Board and insert 6 Cam Fittings into the sockets provided. Then screw 3 Connecting Bolts into holes at the bottom edge of the Head Board.

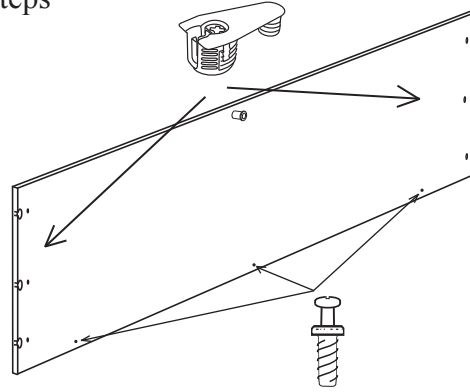

Storage Head board step B: Locate the Head Board bottom and insert 7 cam fittings into the sockets provided.

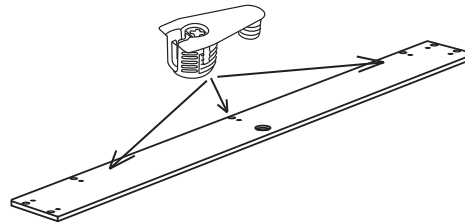

Step 6: Lay the right Side Board down and screw 14 Connecting Bolts into the holes provided as shown. Repeat the process with the left Side Board which will require 15 Connecting Bolts.

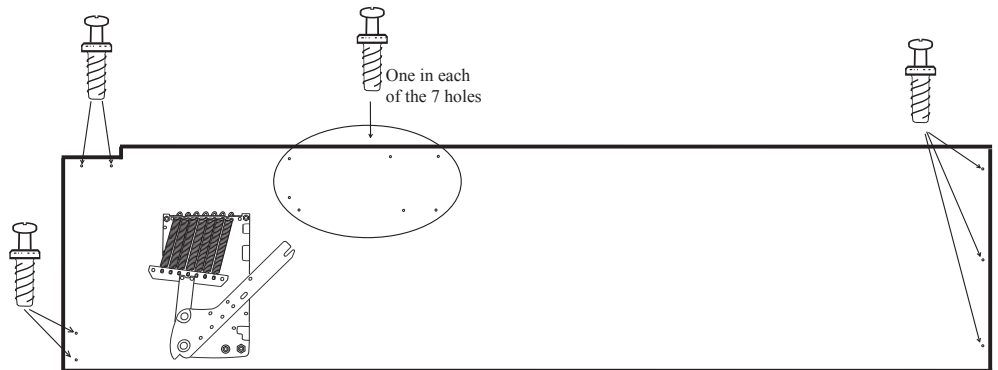

Working with Cam Fittings

In the next three steps you will work with Cam Fittings and Connecting Bolts in attaching cabinet parts together. Take a minute and review this information for ease of assembly.

- Slide the Cam over Connecting bolt.
- Hold parts snug together.
- Turn Cam Fitting 1/2 turn clockwise with a manual screw driver. **DO NOT USE POWER SCREW DRIVER.**

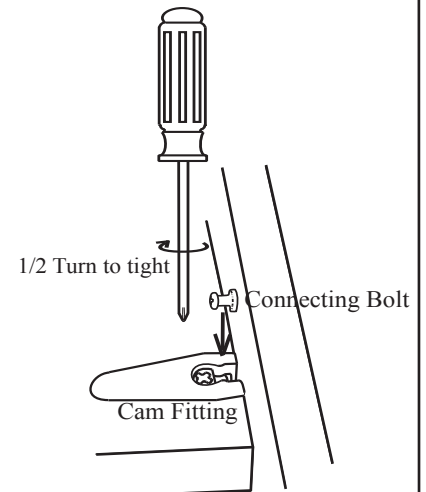

Step 7: Assemble the Bed Cabinet face down with the bottom of the bed nearer the wall to which it will be installed by connecting Bridge Board, Head Board, and the two Stretchers as illustrated.

NOTE: The front stretcher is positioned so the cam fittings are on the BOTTOM of the bed.

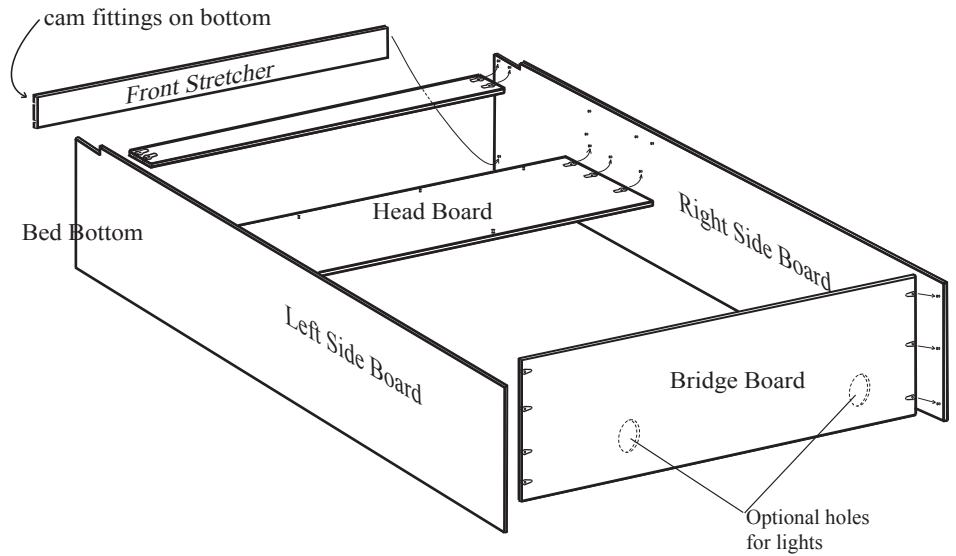

Storage Head board steps

Storage Head Board Step C: Insert the Head Board bottom into position as illustrated. Note the cam fittings are facing down toward bed bottom.

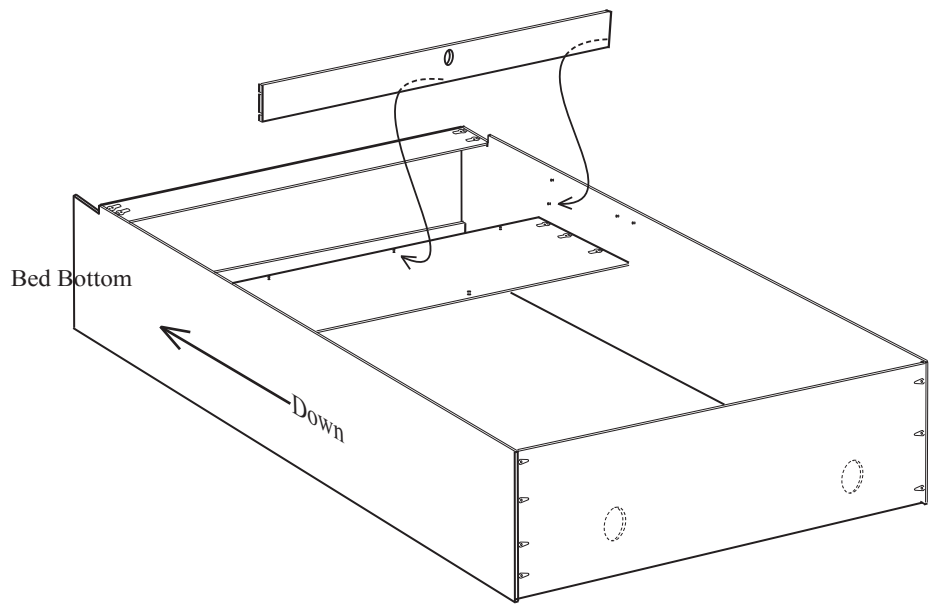

Storage Head Board D: Install the hinged storage door unit as illustrated.

Helpful hint: Lift the center section to get the unit positioned correctly

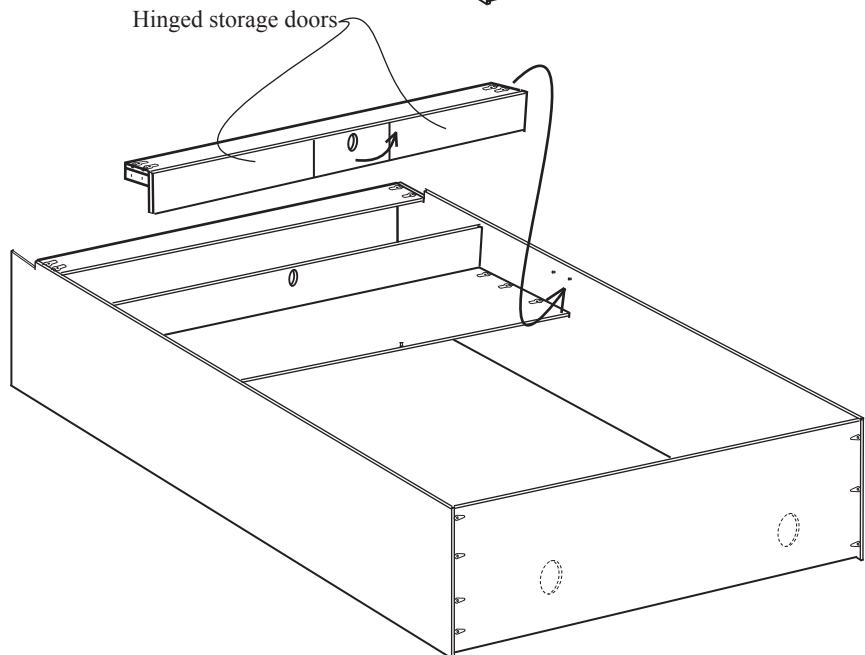



IF YOU PURCHASED LIGHTS FOR YOUR WALLBED YOU MUST REFER TO THE LIGHT KIT INSTRUCTIONS AND INSTALL THE LIGHT KIT BEFORE MOVING ON.

(Light Kit instructions are in the Light Kit box)

Step 8: Stand the bed cabinet up against the wall where you intend to have it installed.

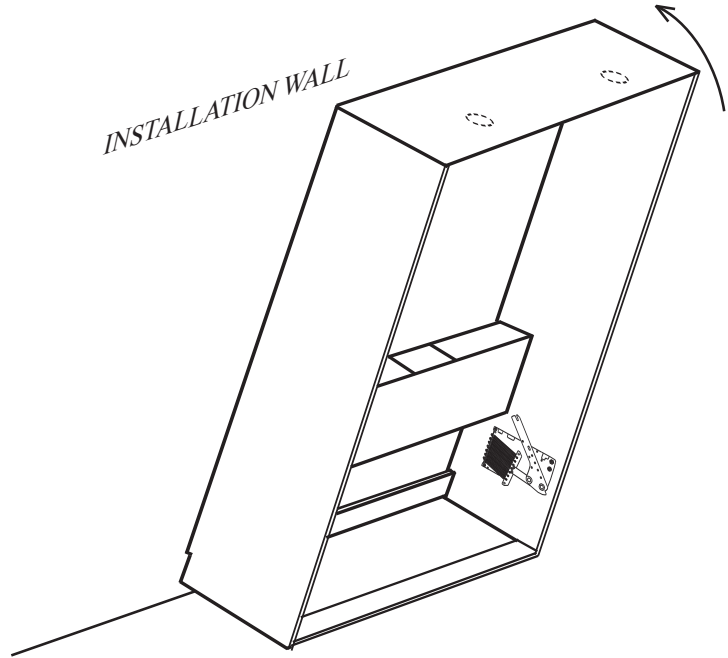

Storage Head board step

Storage Head Board Step E:
With Bed cabinet in the standing position open the storage head board on both sides and insert two 1 1/4" gold screws in either side of the lid support through holes provided as shown.

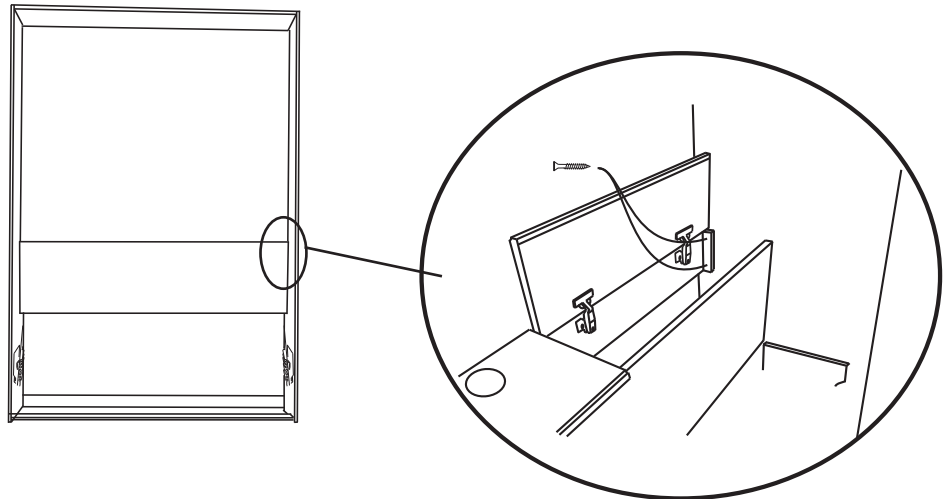

WARNING! THE NEXT STEP MAY REQUIRE PROFESSIONAL HELP.

IF YOUR WALLS ARE NOT TRADITIONAL WOOD FRAMING, YOU MAY NEED TO HIRE A HANDY MAN OR CONTRACTOR TO HELP IN ANCHORING THE BED TO YOUR WALL. FAILURE TO PROPERLY ANCHOR CABINET COULD CAUSE SEVERE PERSONAL INJURY. CALL TECHNICAL SUPPORT AT 866-725-6401 IF YOU HAVE ANY QUESTIONS.

Hardware needed for next step from Bag #10

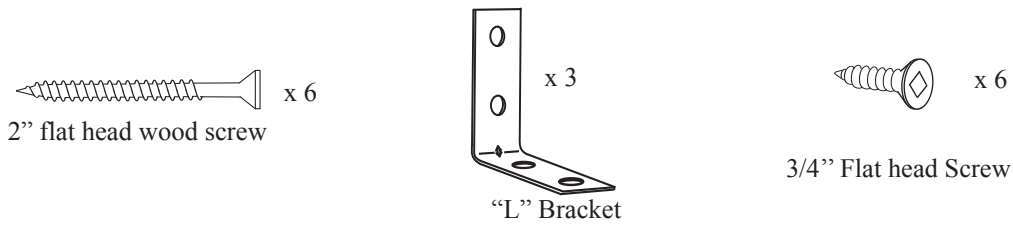

Step: 9: Using a Stud Finder locate and mark the studs in the wall behind the bed. Attach the "L" brackets to the top of the Bed Cabinet corresponding to where the studs are located. Now attach the "L" brackets to the studs in the wall. See illustration 6

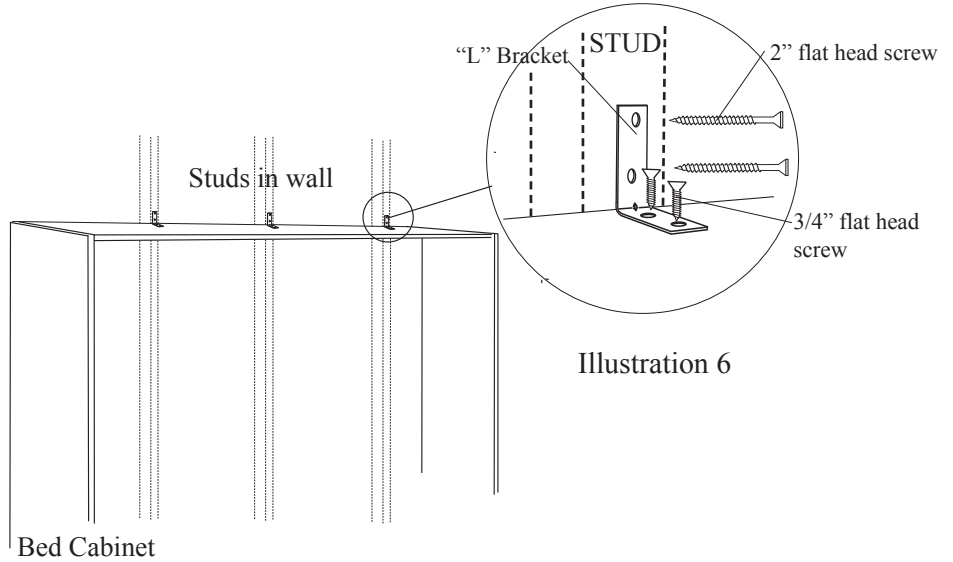

IMPORTANT! King Queen and Full size beds require 3 studs, Twin size beds require 2 studs. It is VERY important that the bed be anchored securely to the wall. If bed is not anchored properly the bed can fall causing SERIOUS injury. For technical support call 866-877-7803 toll free.

Step 10: Locate the Front Panel(s) and lay them on the floor face down (finished side). Position them in front of where the Bed Cabinet was installed and leave enough room to work around them.

Important note: place panels with handle holes as illustrated

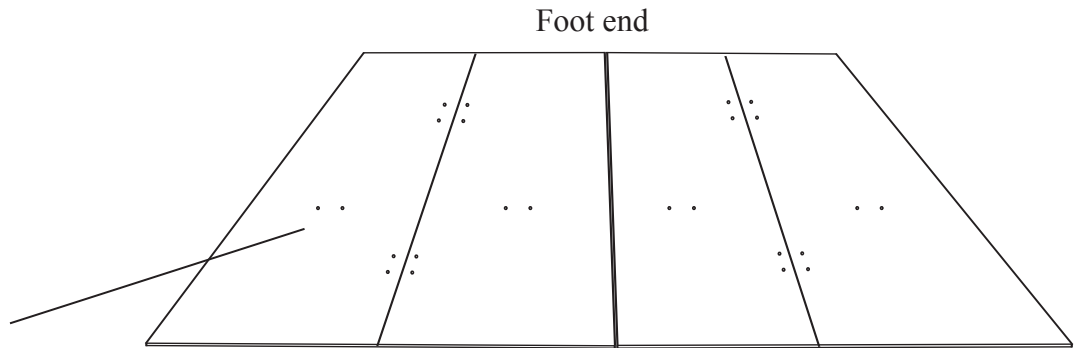

Step 11: Arrange the mattress rails on the face panels as shown.

HELPFUL HINT: the "Head Rail" refers to the end that is closest to the Bed Cabinet while assembling and will be where your head is while sleeping.

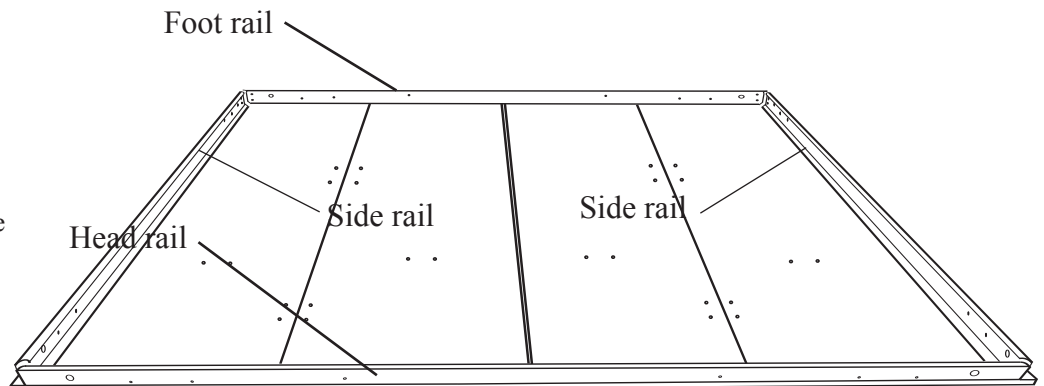

Hardware needed for next 2 steps from bag #14

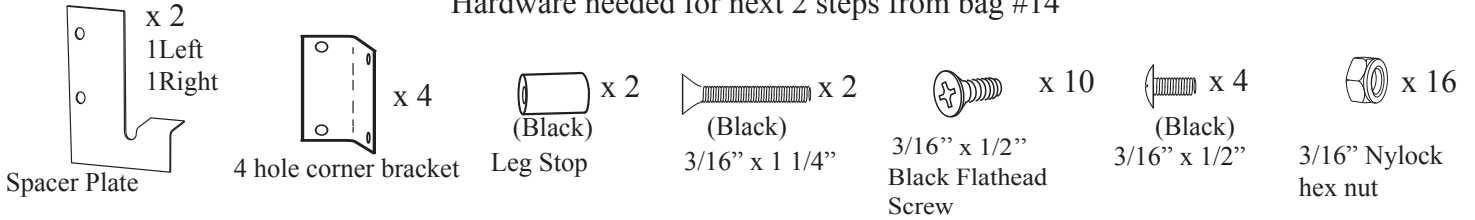

Step 12: From hardware bag 14 locate the hardware shown above. Finger tighten the hardware as shown in illustration 7 attaching two of the 4 hole corner brackets on the foot rail end of the mattress frame. Note the lower hole on each side rail uses the Leg Stop with the longer screw (3/16" x 1 1/4"). Repeat on the opposite foot rail corner.

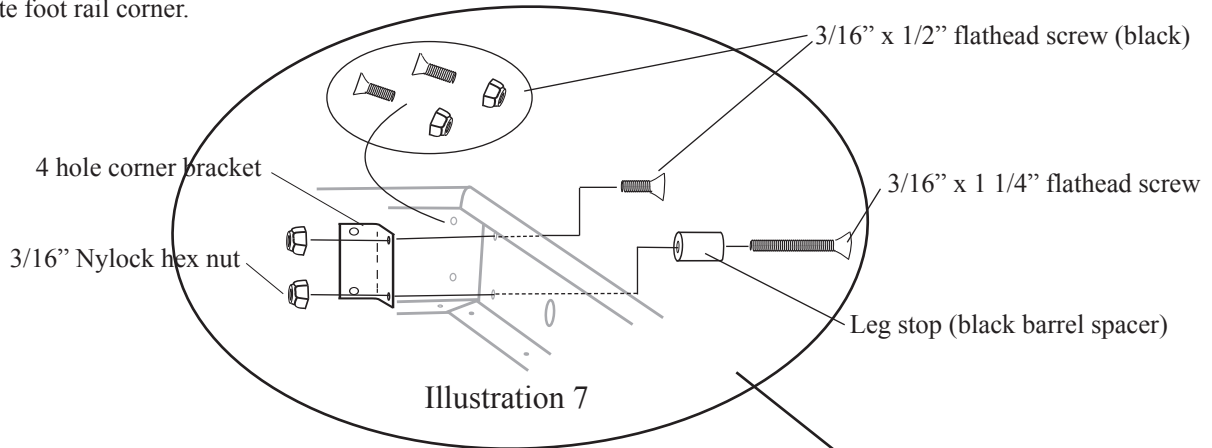

Step 13: Finger tighten the hardware as shown in illustration 8 attaching two of the 4 hole corner brackets on the inside Head Rail end of the Mattress Frame. Note the spacer is attached on the outside. Repeat opposite Head Rail corner.

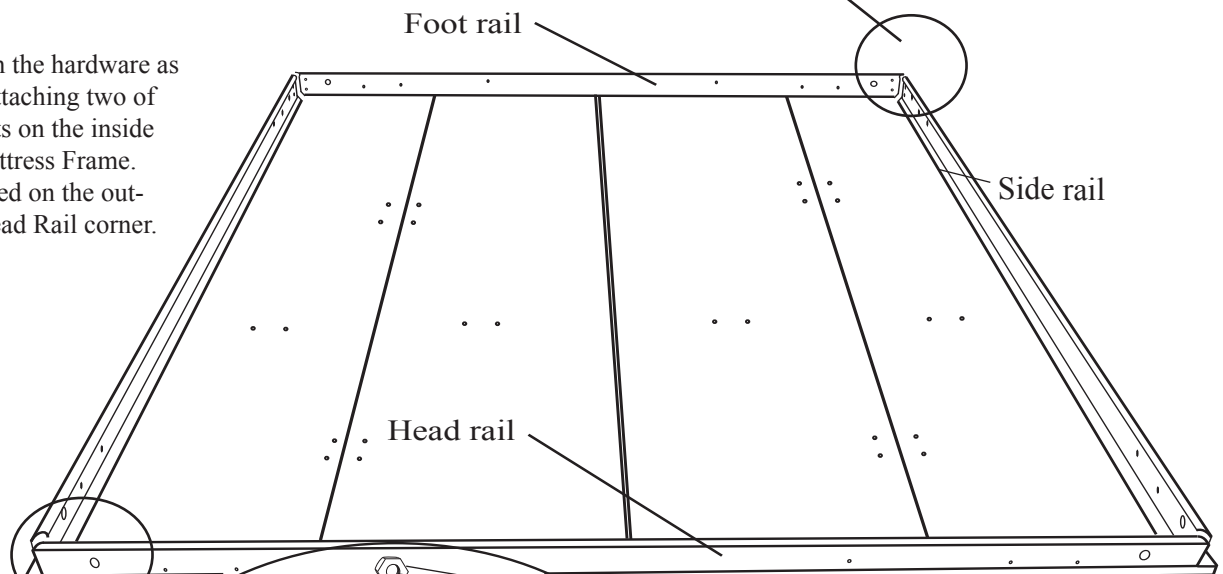

Step 14: Once all sides are finger tight go back to each corner and align the corners as they are tightened using either a 3/8" socket or wrench and a Phillips screw driver.

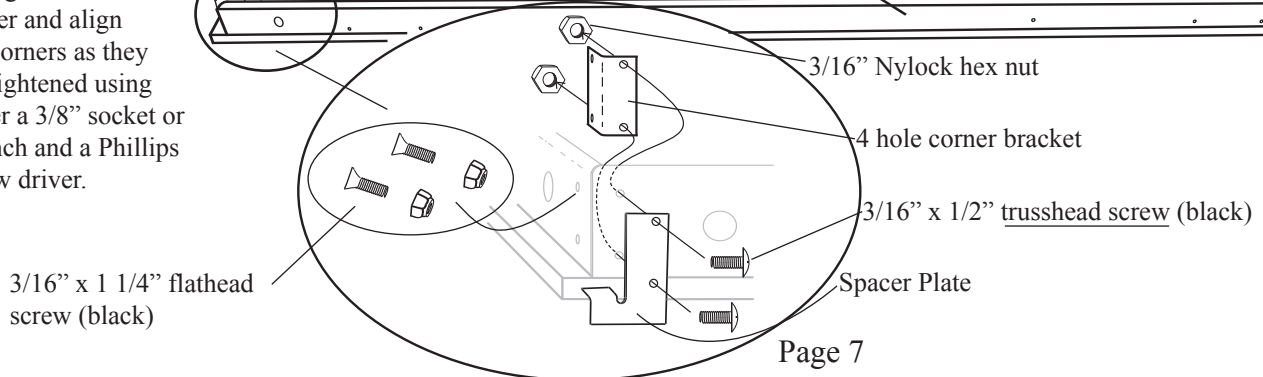

Hardware and parts needed for next steps

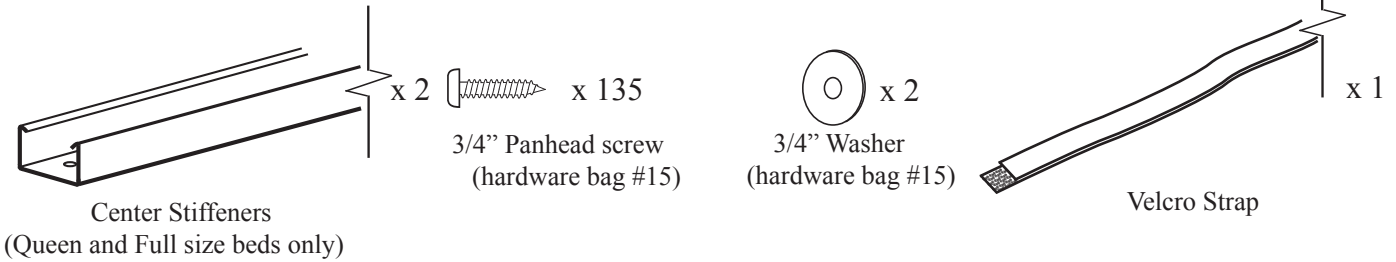

Step 15: Using the Spacer Plates as a reference at the head of the Bed Frame, align the Side Rails and the Face Panels. For proper alignment the Head Rail should be flush with the head of the Face Panel and the Side Rails should have a 1" offset top to bottom on both sides. See illustration 9.

Step 16: Place the Center Stiffeners across the Bed Panels overlapping them on to the Side Rails and spaced equally to divide the Bed Panels in three equal sections. See illustration 10

Note: the stiffeners will overlap the horizontal flange of the Side Rail but DO NOT reach all the way to the vertical members. Also the holes in the ends of the Stiffeners DO NOT line up with the holes in the Side Rails.

Step 17: Using the 3/4" pan head screws secure the Bed Frame to the Face Panels using 1 screw in each corner ensuring that the frame and panels are square to each other. Once the Frame is secure insert the balance of the screws around the Frame and across the Stiffeners.

Attach the Velcro Straps (for holding the mattress in place) about 18" from the foot of the bed. Put the hooks part of the strap on one side of the bed and the loops part of the strap on the other side. Insure that the hooks and loops will face each other and interlock. see Illustration 11

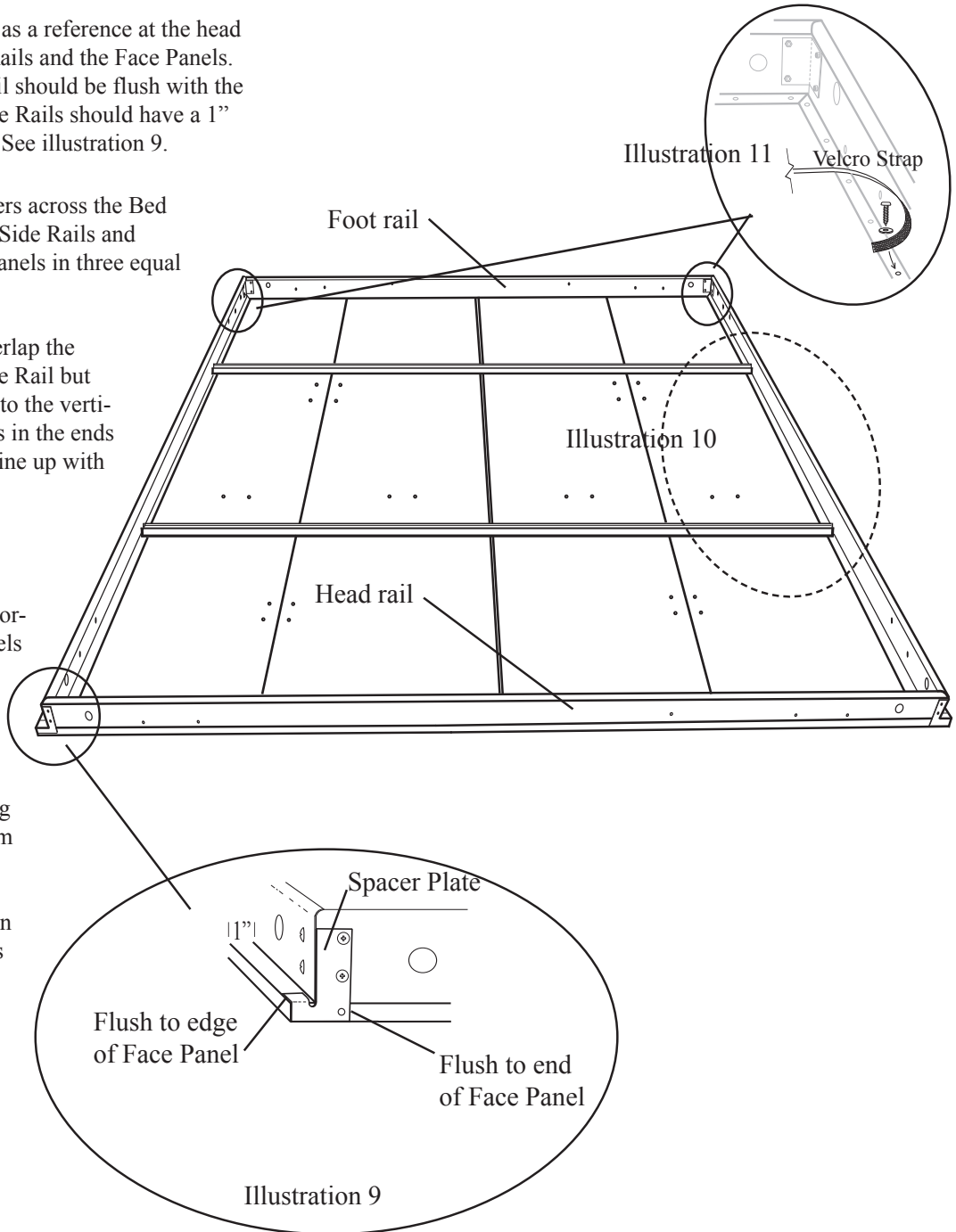

IMPORTANT! When attaching the Frames and Stiffeners, we recommend that you power drive screws only part way and then tighten by hand.
DO NOT STRIP SCREWS.

Hardware needed for next step from hardware bag #14

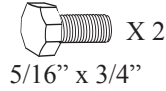

Step 18: As illustrated below, insert the Allen Key Bolt through bolt hole # 1 and tighten it down securely using a Nylock Nut. Now insert a 5/16" x 3/4" Hex head bolt through hole # 3 and thread the Nylock nut ONLY UNTIL IT IS FLUSH WITH THE BOLT END. Bolt hole #2 will be used in a later step.

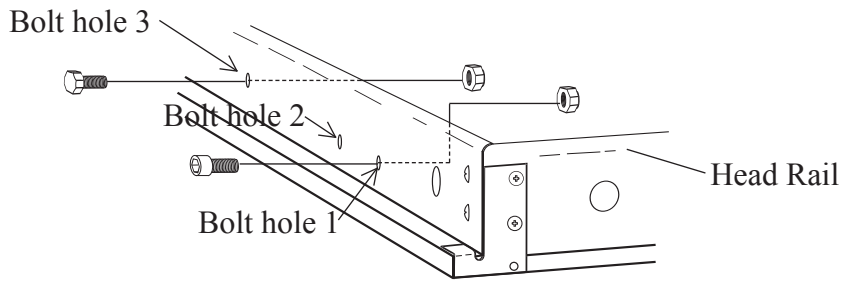

Hardware needed for next step from hardware bag #14

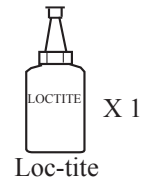
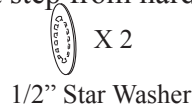
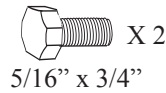

Step 19: Assemble Legs by first removing the nut and the first TWO washers that come pre-installed on the Leg. Leave the washer with a black edge and the thin plastic washer in place on the leg. Insert the Leg Bolt with the first two washers through the Side Rail. DISCARD the thick silver washer then place the black washer and the nut back on the Leg Bolt and tighten.

Step 20: Position the Cross Bar between the Legs. Place 1/2" Star washer on one of the 5/16 X 3/4" Hex Head bolts apply 2 drops of Loc-tite and thread the bolt through the Leg and into the Cross Bar and tighten. Repeat on other side.

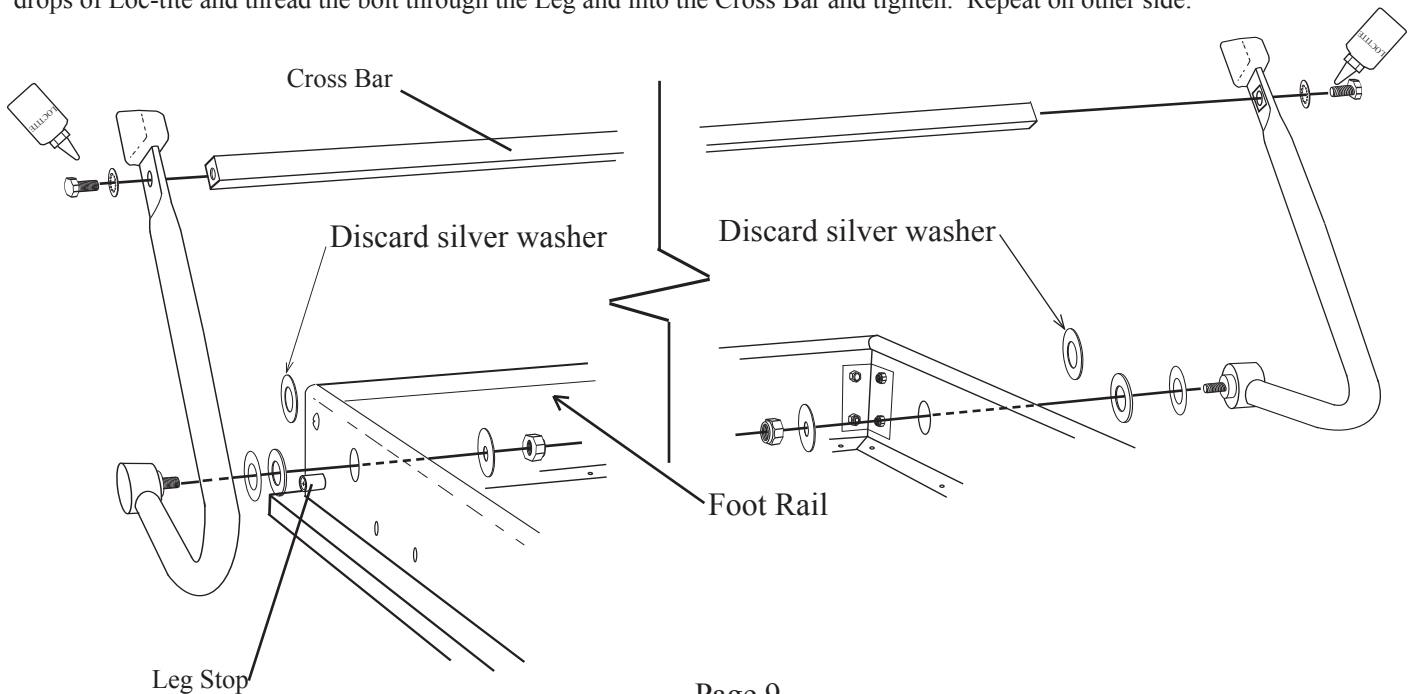



IF YOU PURCHASED LIGHTS FOR YOUR WALLBED YOU MUST RETURN TO THE LIGHT KIT INSTRUCTIONS STEP 6 AND INSTALL THE SAFETY CUT OFF DEVICE BEFORE MOVING ON.

Step 21: Brace one foot against the front edge of the side board and using the 13" length of PVC tubing provided, pull the lift mechanism tension arm out and down until you can secure the arm lock to the hexagon nut shown to right. BE SURE THAT THE LOCK IS SECURED AGAINST THE HEX NUT BEFORE RELEASING THE TENSION ON THE LIFT MECHANISM.

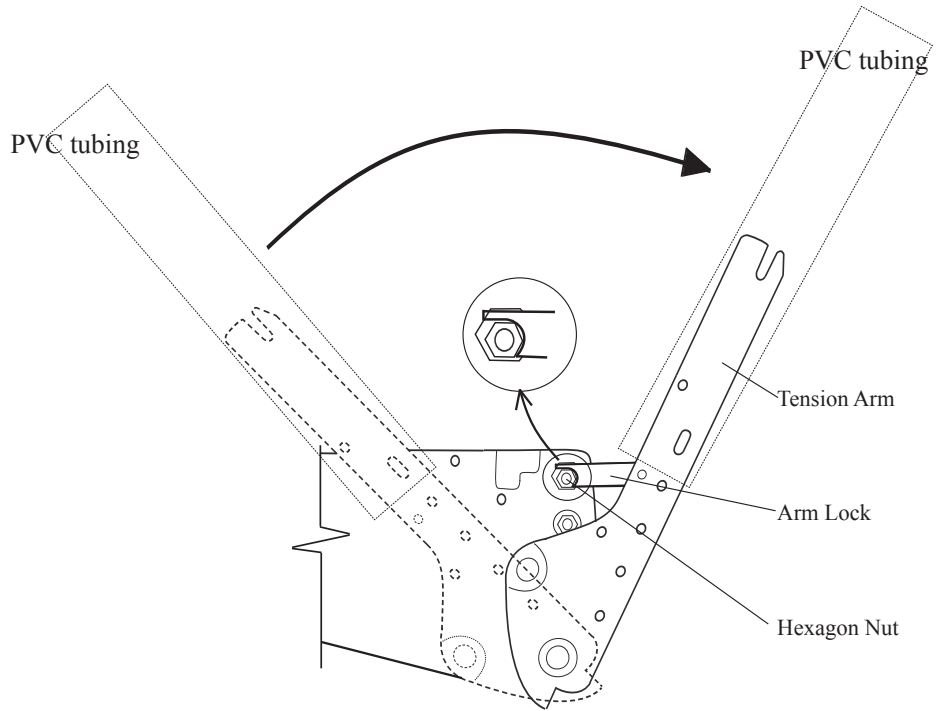

CAUTION! There will be a lot of tension on the Tension Arm. We recommend that two people handle this procedure - one pulling and holding the Tension Arm with both hands while the other sets the Arm Lock. When setting the Arm Lock, DO NOT reach behind the Tension Arm.

IMPORTANT! As instructed in step 18, Bolt #3 should be loose enough to slip into the notch at the end of the Tension Arm See illustration below.

Step 22: Stand the Bed face unit up on its Head Rail end. Now with you and your assistant on either side of the Bed face unit lift until the # 3 bolt on the Bed face unit is a few inches above the slotted end of the Tension Arm on both sides. Gently lower the Bed face unit between the Tension Arms and seat the # 3 bolt into the slot at the end of the Tension Arms. Now start pulling the bed face unit down and away from the Bed Cabinet the Allen Key bolt head will seat into the notch at the lower end of the Tension Arms. Lower the bed unit down and pull the Legs down so that they are on the floor. Someone will need to hold the bed unit down as it will want to rise.

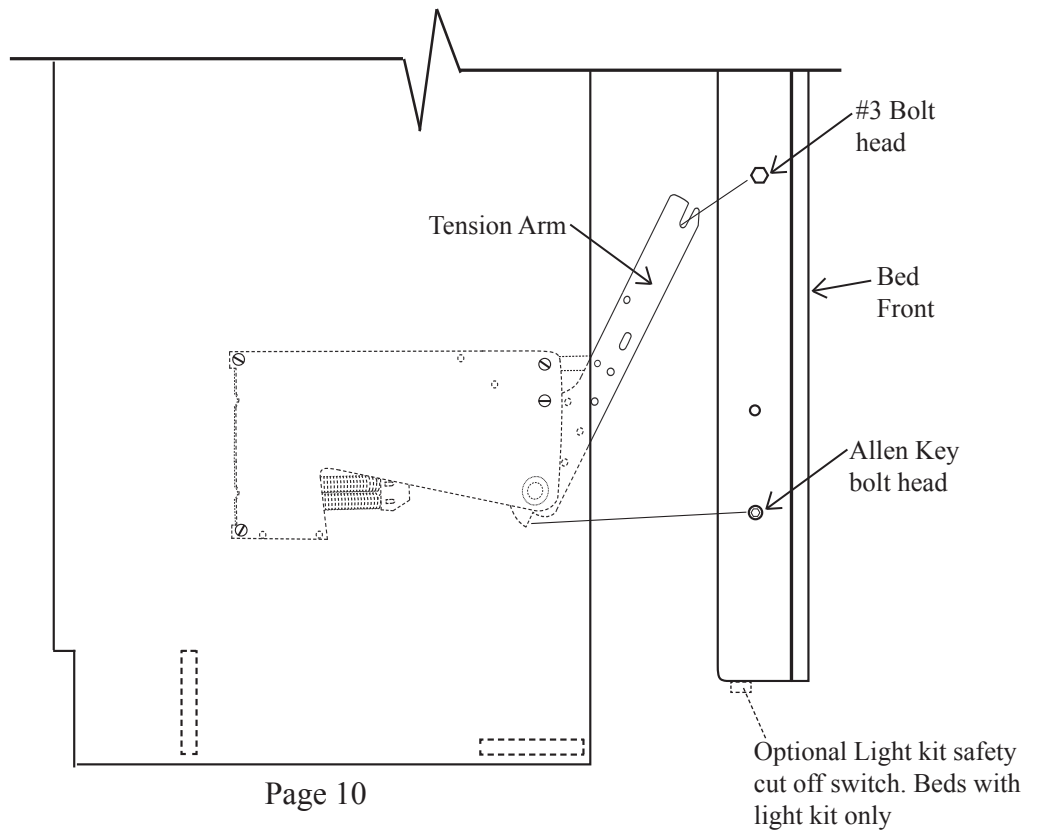

Hardware needed for next step from hardware bag #14



Step 23: Insert a 5/16" X 3/4" Hex bolt through hole #2 and tighten a 5/16" Nylock nut onto the bolt. Now tighten the nut and bolt in hole #3.

Repeat step 23 on the other side of the bed unit.

WARNING! Failure to insert and tighten all the bolts in step 23 could result in **severe personal injury** or damage to the lift mechanism. Lift mechanism damage caused by missing or loose hardware is not covered by warranty.

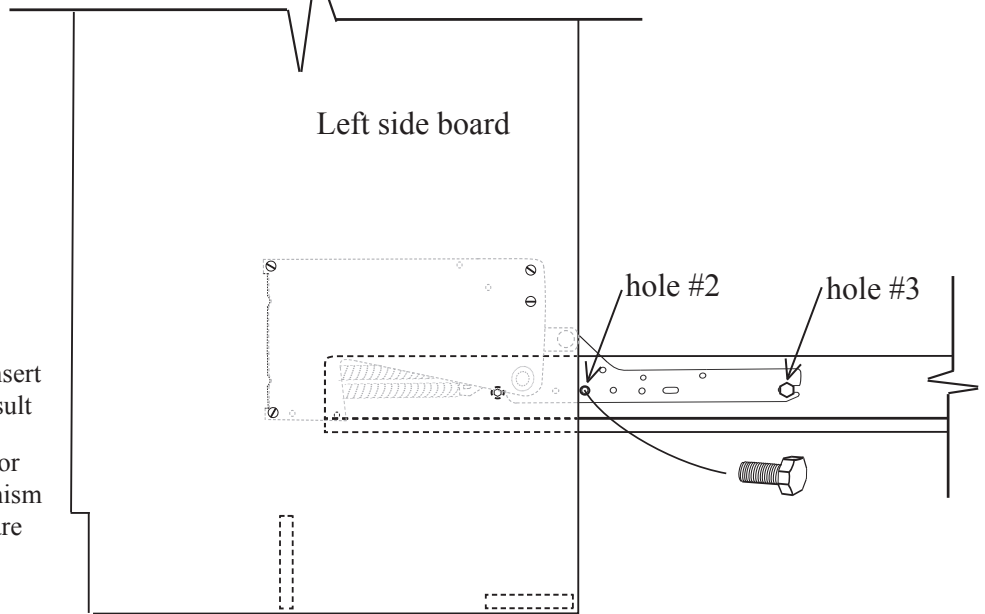

Hardware needed for next step from hardware bag #7



Step 24: Slip the Mechanism Cover over the Mechanism so that the tabs on the cover fit into the notches provided. Line up the holes with the threaded supports and insert two 4mm Flathead screws.

Repeat step 24 on the other Mechanism.

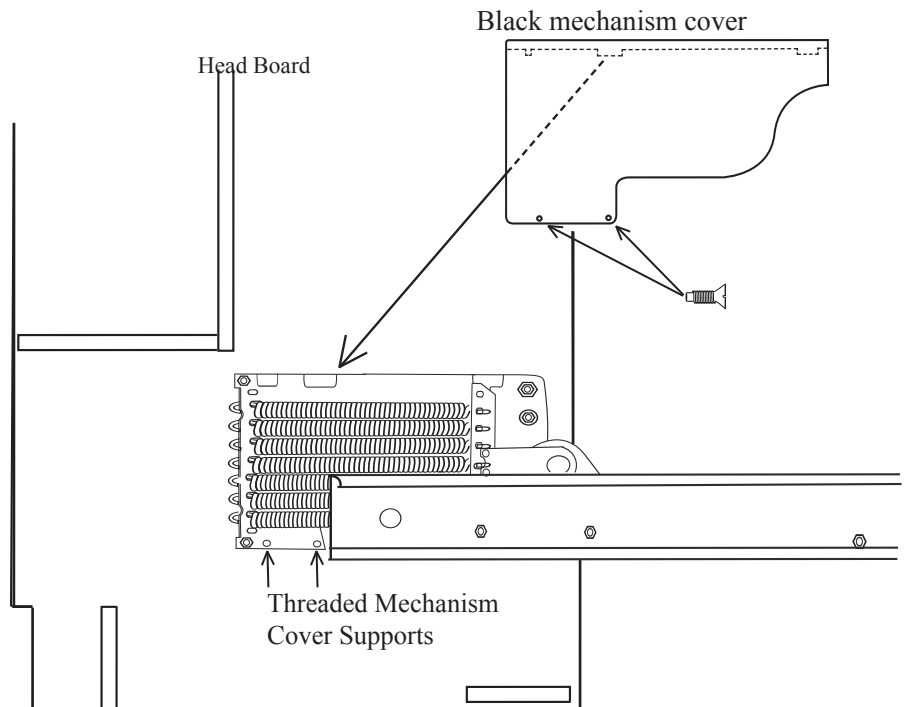

Step 25: When the bed is closed check to see if the gap on either side is the same. If it looks right skip this step. If the gap is not right, meaning that the Bed Box is too close to the side board or even touching it at the top on one side it will need to be adjusted. The procedure will require the bottom of the bed to be moved slightly to the left or right depending on which top corner is too close. If the bed is too close on the top right side for instance, the right side (bottom) will need to be slid to the left slightly (See illustration 12). Have one person push the bed at the bottom with his feet while the second person pulls at the opposite bottom side.

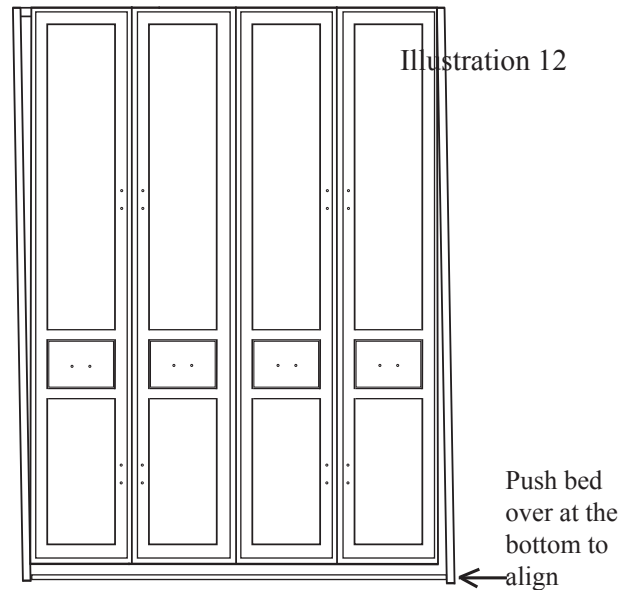

Step 26: Place handles on bed using pre-drilled holes in face panels.

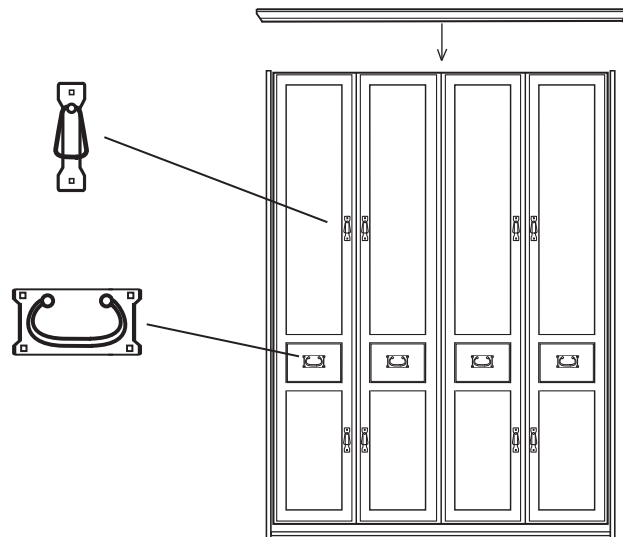

Step 27: Place the crown mold on the bed as illustrated and use the 1 1/4" screws to secure it in place. If you purchased side cabinets apply crown mold to them as well.

Note: Dakota style bed does not have crown molding

Step 28: Anchor the Side Cabinet to the Bed by first pre-drilling three 3/16" holes at the inside edge of the side cabinet. Position the holes close to the front edge of the Side Cabinet. One hole should be near the top, one should be inside the drawer area (remove drawer from cabinet to get to this one), and the third should be at the bottom (open door if your cabinet has door, or remove drawer at bottom) for this hole. Now move the side cabinets next to the bed and use three 1 1/4" Gold Screws (located in a drawer or on a shelf of the side cabinet) through pre-drilled holes to anchor Side Cabinets to the Bed.

