

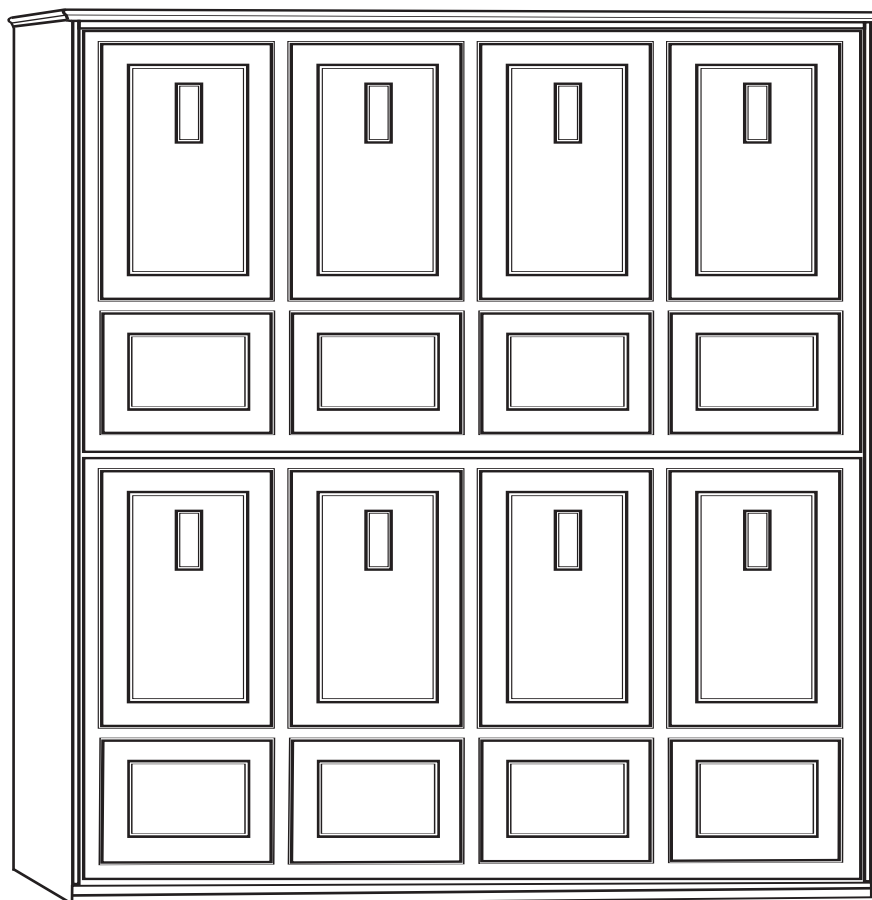



WILDING WALLBEDS BUNK BED INSTALLATION INSTRUCTIONS

INSTRUCTION BOOKLET #18

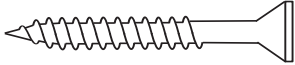
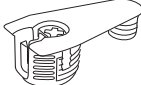

WARNING! ALL MURPHY/WALLBED SYSTEMS CONTAIN POWERFUL LIFTING COMPONENTS . FAILURE TO USE AND FOLLOW THESE INSTRUCTIONS DURING THE INSTALLATION PROCESS COULD RESULT IN SEVERE PERSONAL INJURY TO USER OR DAMAGE TO PRODUCT. PLEASE CONTACT CUSTOMER SERVICE AT 866-725-6401 FOR ANY QUESTIONS.

Hardware Supplied

QTY	SIZE	
4	3 1/2" Grabber	
6	1 1/2" Grabber	
6	Cam Fitting (extras)	
6	Connecting Bolt (extras)	

Tools Needed

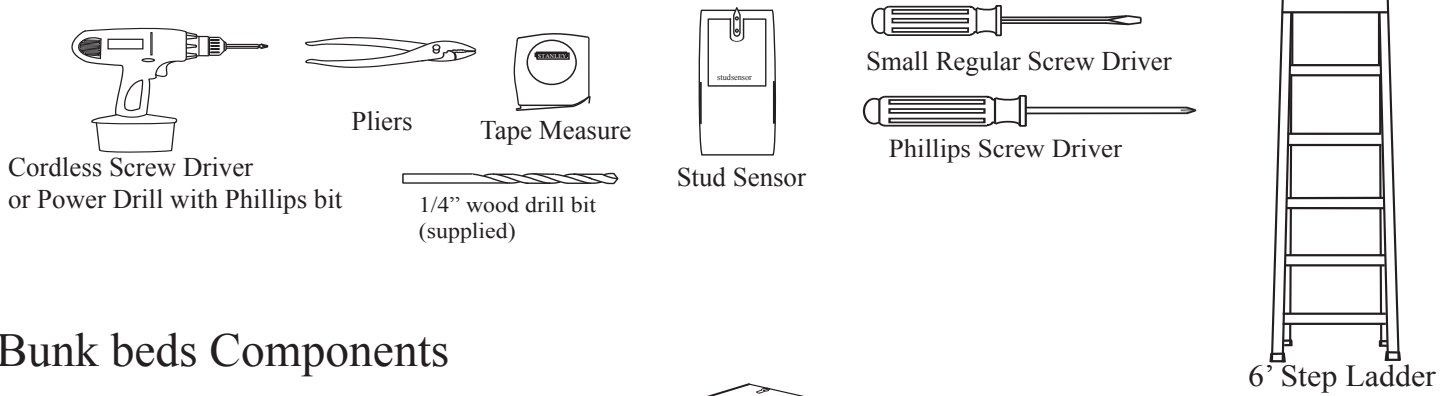

Bunk beds Components

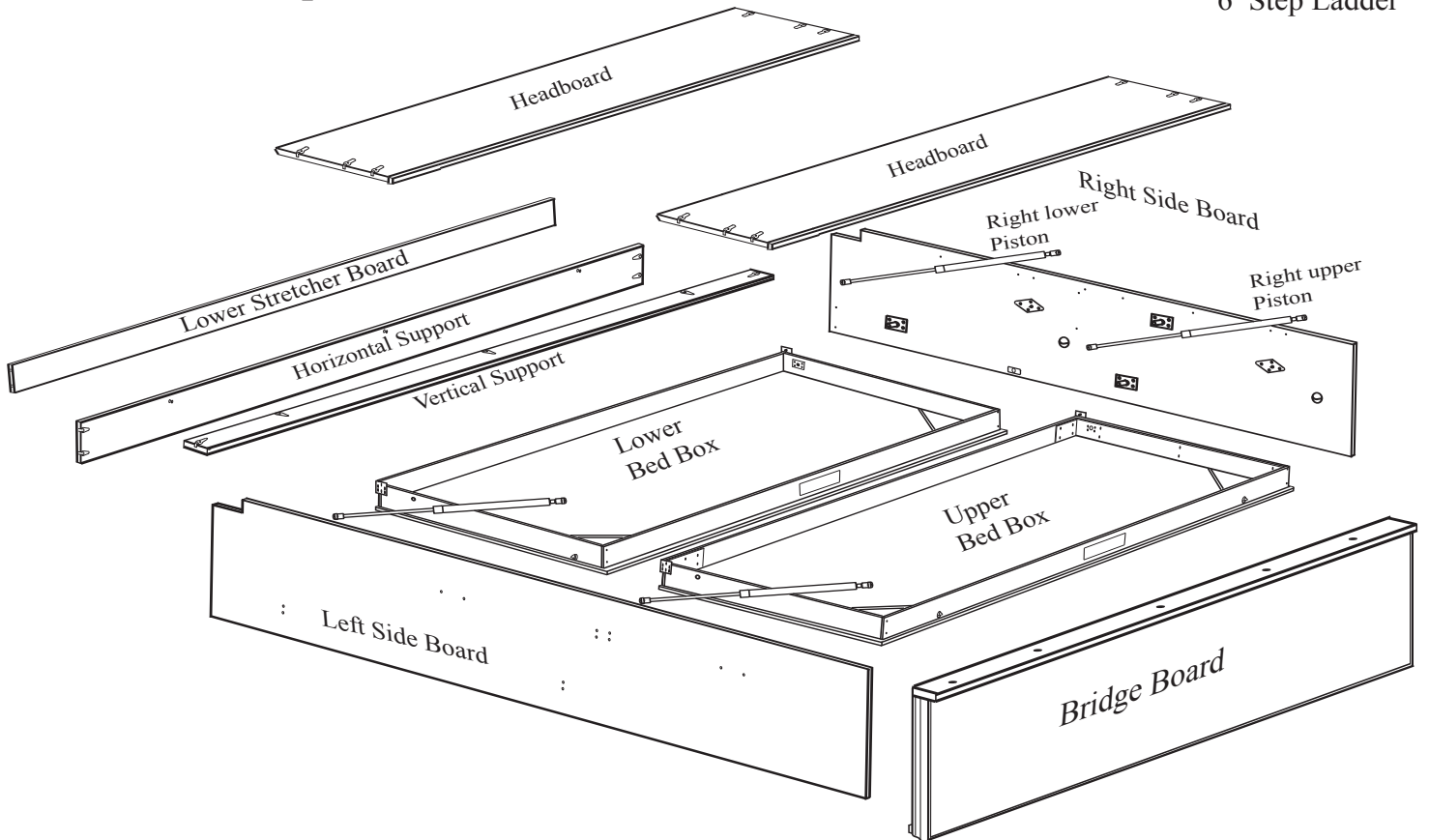

Step 1 Remove the four bed stops (2 from each side board). They will be re-attached in a later step.

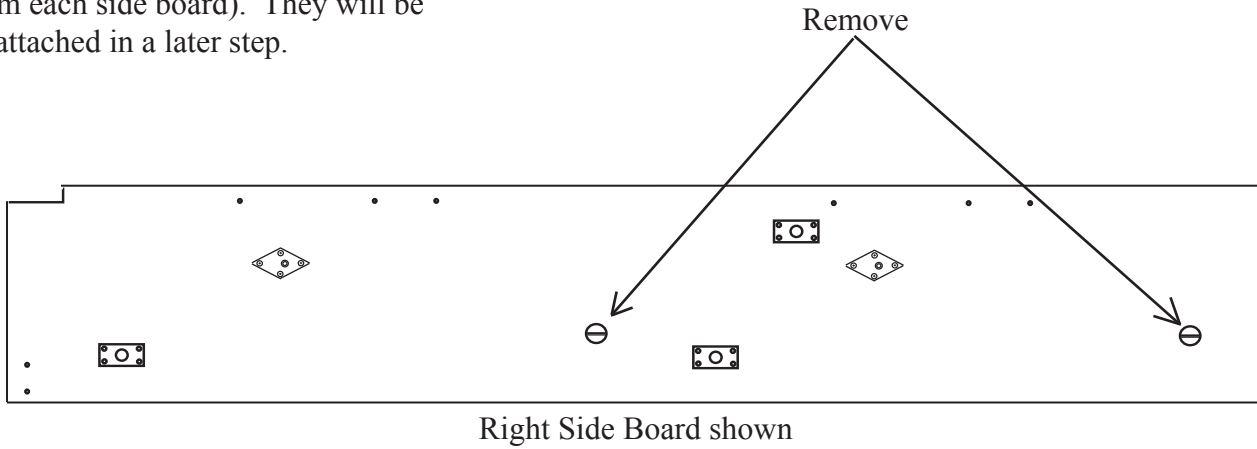

Step 2: Position LOWER BUNK* ONLY and the right and left side boards in your room with the lower bunk closest to the wall the bunk bed will be installed against.

***IMPORTANT NOTE:** THE UPPER BUNK HAS METAL STRONG ARMS ON THE INSIDE OF THE BED BOX WHERE THE MATTRESS WILL BE PLACED. MAKE CERTAIN YOU ARE PUTTING THE BUNKS IN THE RIGHT POSITION.

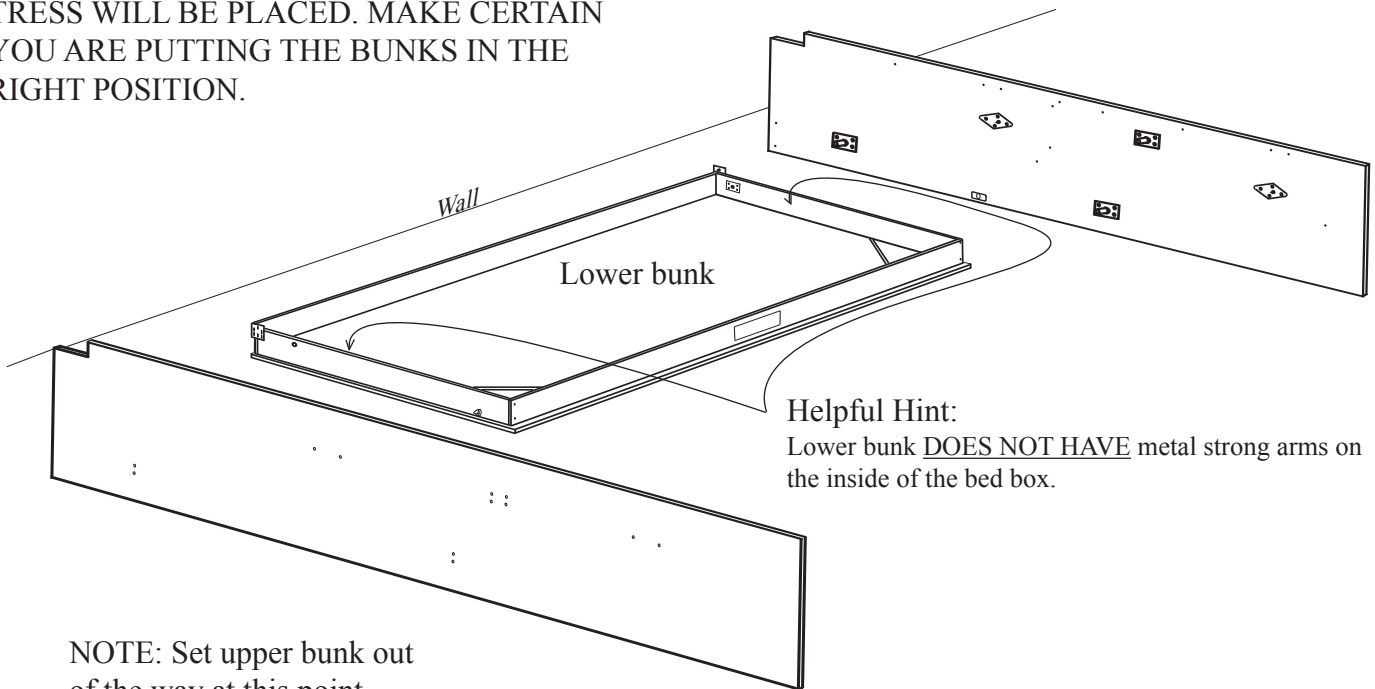

Helpful Hint:
Lower bunk DOES NOT HAVE metal strong arms on the inside of the bed box.

NOTE: Set upper bunk out of the way at this point.

Step 3: With a pair of pliers, or a small regular screw driver, remove the E-clips from pivot posts on the side boards. Leave the white nylon spacers in place on the pivot posts.

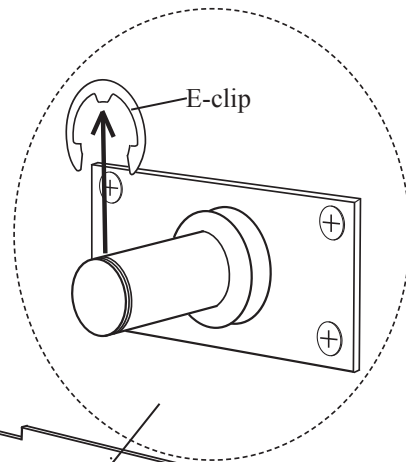

Step 4: Slide the side board pivot posts through the pivot holes in the bed box as shown. Then replace the E-clips by snapping them back onto the Pivot Posts.

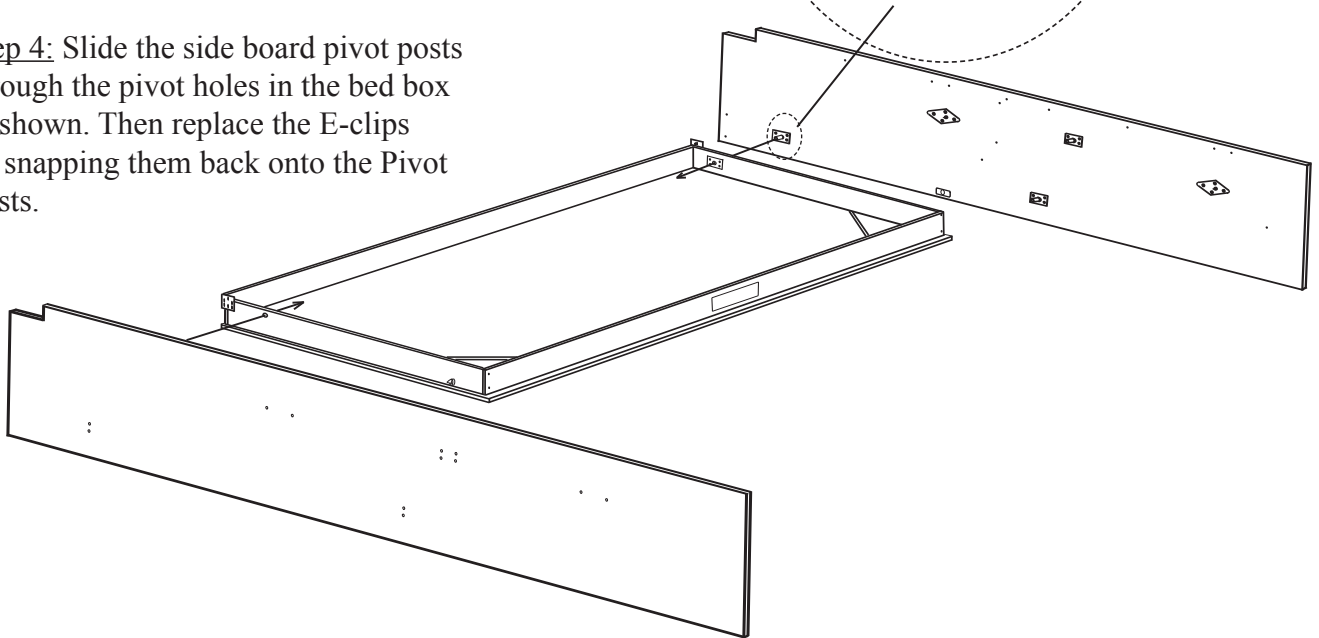

Step 5: Attach the lower end of the lift piston (skinnier end) onto the lower anchor plate on both sides of the bed box by positioning the socket end of the piston directly over the anchor ball and pushing them into place. The piston socket should snap into place over the anchor ball.

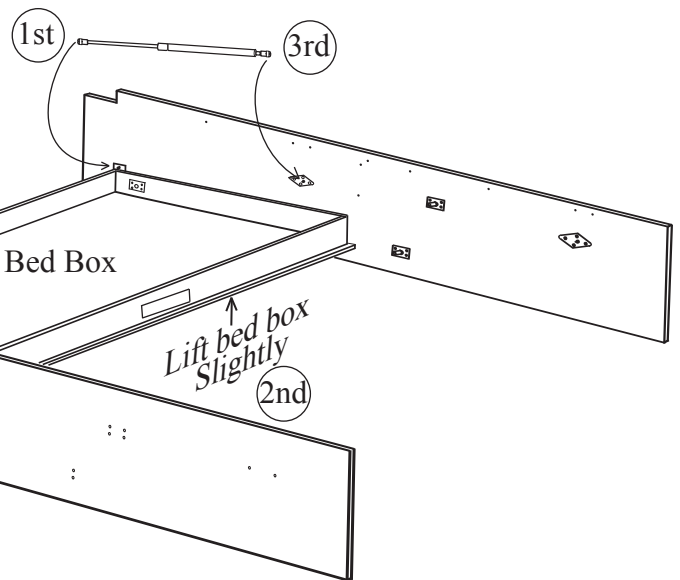

Step 6: This step will require two people. One person will need to kneel down in front of the bed box and lift it up about 3 to 5 inches. The second person will position the upper socket end of the lift piston directly over the anchor ball on the upper anchor plate and snap it into place. The first person may need to raise and lower the bed box slightly to allow the piston to line up and snap on. Repeat step 6 for the opposite piston to be snapped into place.

Step 7: Remove the E-clips from upper bunk pivots post. Spread the side boards and gently maneuver the upper bunk into place then replace the E-clips

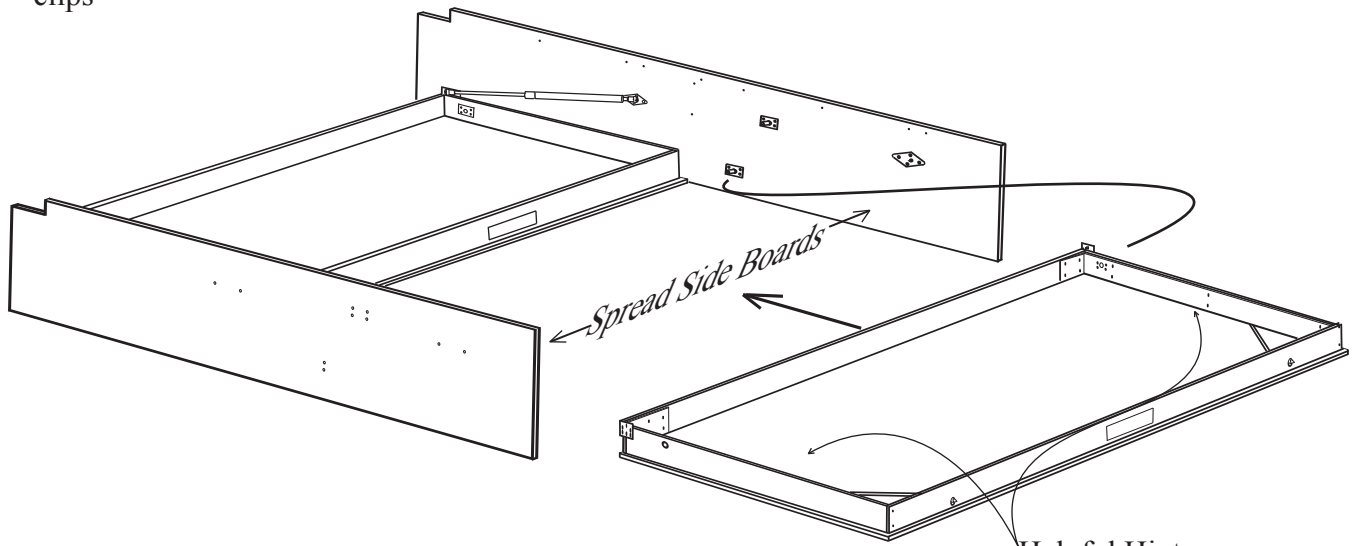

Step 8: Attach the lower end of the lift piston (skinnier end) onto the lower anchor plate on both sides of the bed box by positioning the socket end of the piston directly over the anchor ball and pushing them onto place. The piston socket should snap into place over the anchor ball.

Step 9: This step will require two people. One person will need to kneel down in front of the bed box and lift it up about 3 to 5 inches. The second person will position the upper socket end of the Lift piston directly over the anchor ball on the upper anchor plate and snap it into place. The first person may need to raise and lower the bed box slightly to allow the piston to line up and snap on. Repeat step 6 for the opposite piston to be snapped into place.

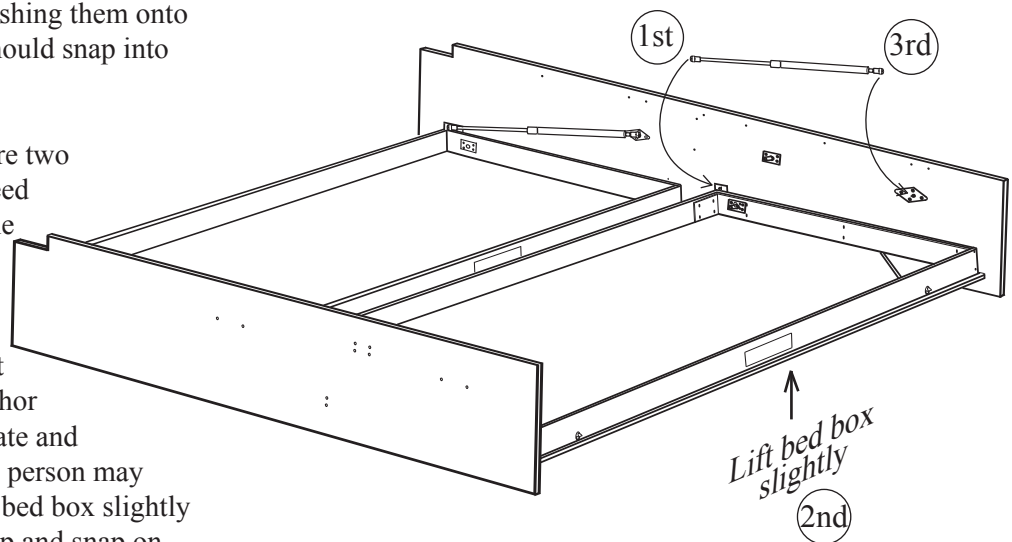

Step:10 With help, slightly lift the side boards and re-attach the bed bumpers on the TOP bunk only. After the bumpers are attached, rest them on the bed side rails.

Helpful hint: place something soft under the side board to support it as you re-attach the Bed Bumper.

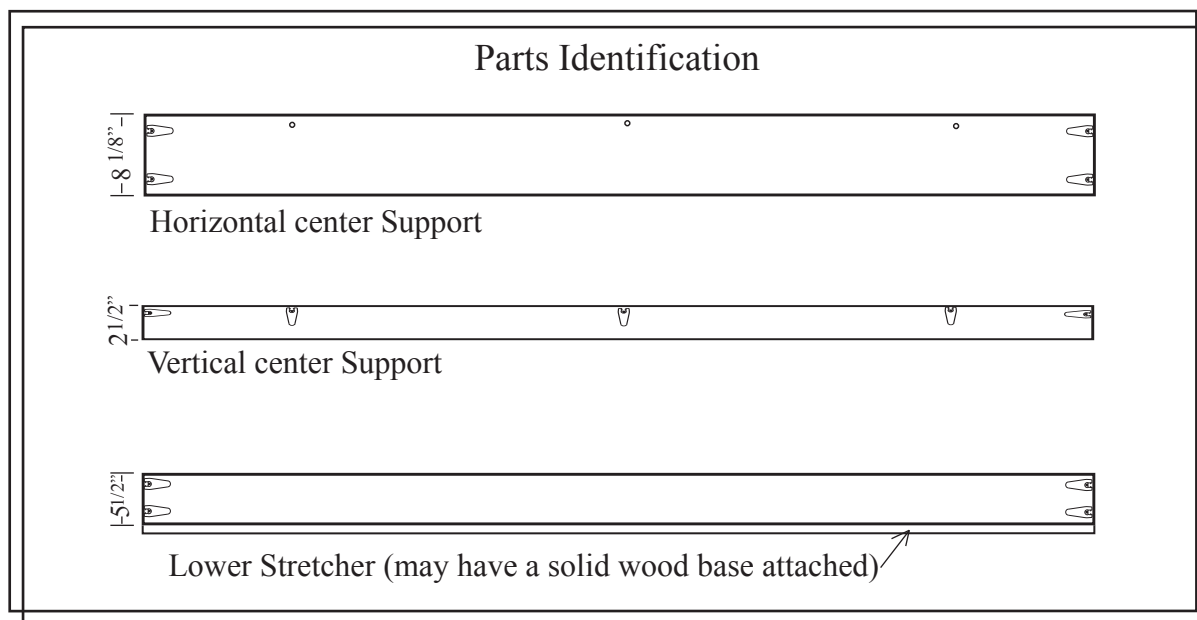
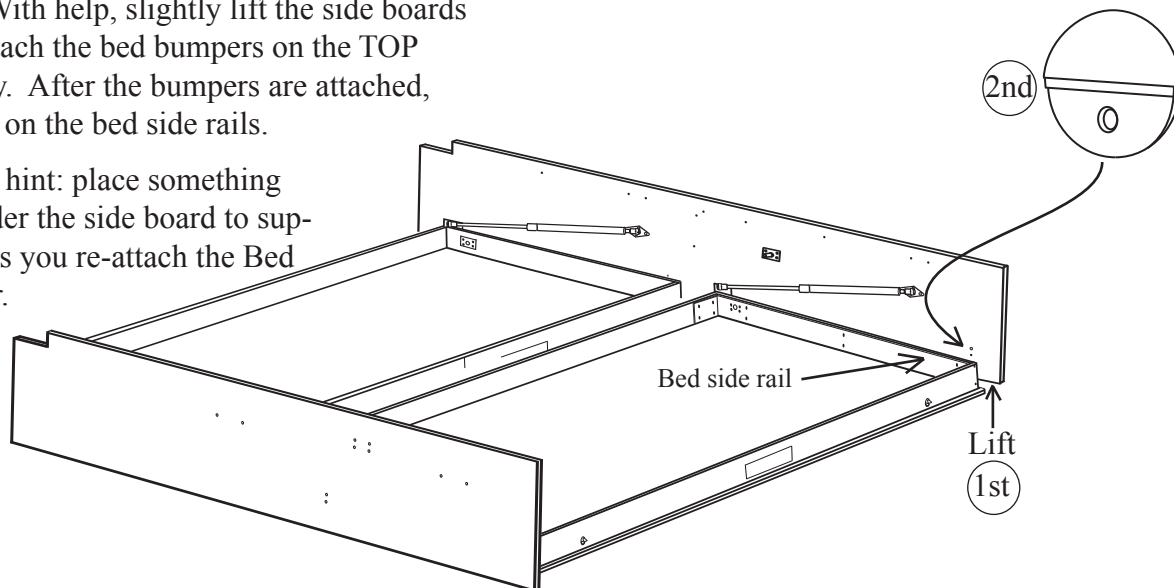

Step:11 Locate the lower stretcher board and separate the stretcher and base mold by removing the screws from the stretcher LEAVE THE “L” BRACKETS ATTACHED TO THE BASE MOLD.

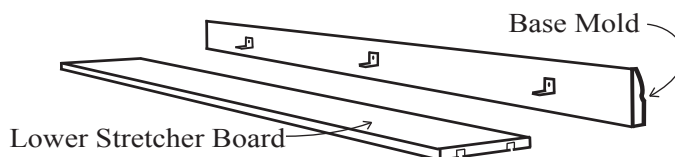

NOTE: Chalet and Silhouette models have no Base Mold.

Cam fitting information

Cam fittings tighten by a 1/2 turn to the right (clockwise). They will pull the parts together and do not need to be over tightened.

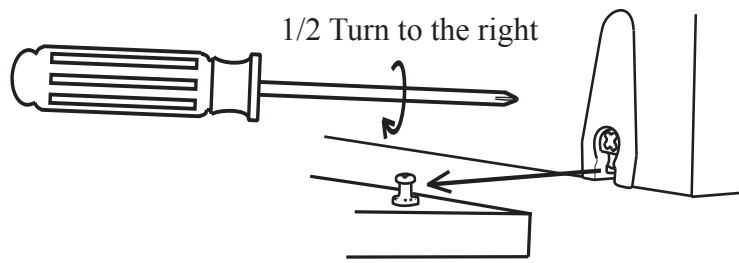

Step 12: Slide the lower stretcher board between the side boards at the bottom of the bunk bed unit. Insert the connecting bolts into the cam fittings and tighten them by turning the cam clockwise. Do this procedure by hand **DO NOT USE A POWER SCREW DRIVER.**

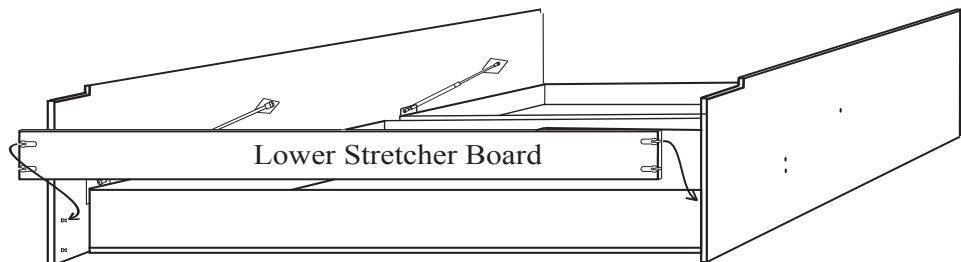

Step 13: Insert the horizontal center support as illustrated and tighten the cam fittings. Do this procedure by hand DO NOT USE A POWER SCREW DRIVER.

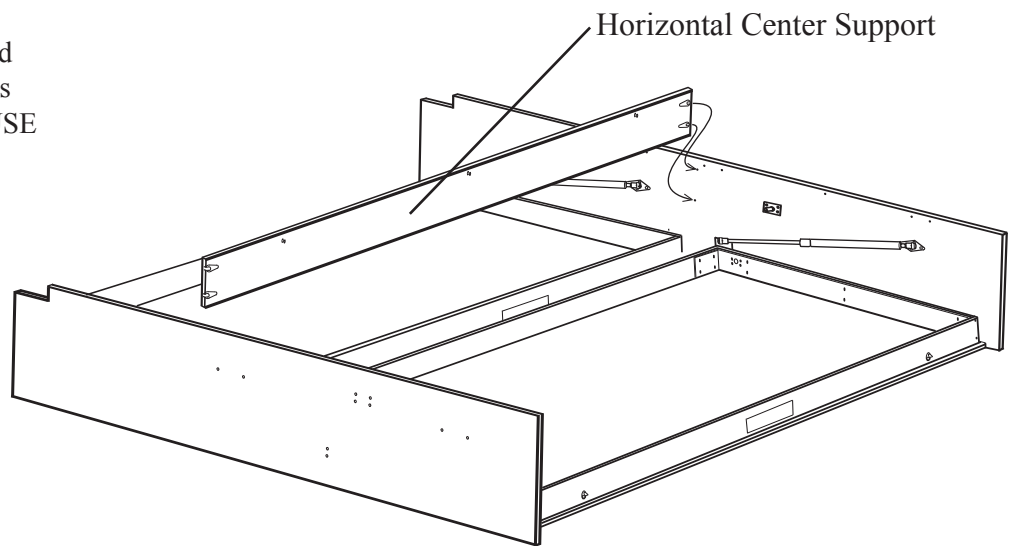

Step 14: Insert the vertical center support as illustrated and tighten the cam fittings. Do this procedure by hand DO NOT USE A POWER SCREW DRIVER.

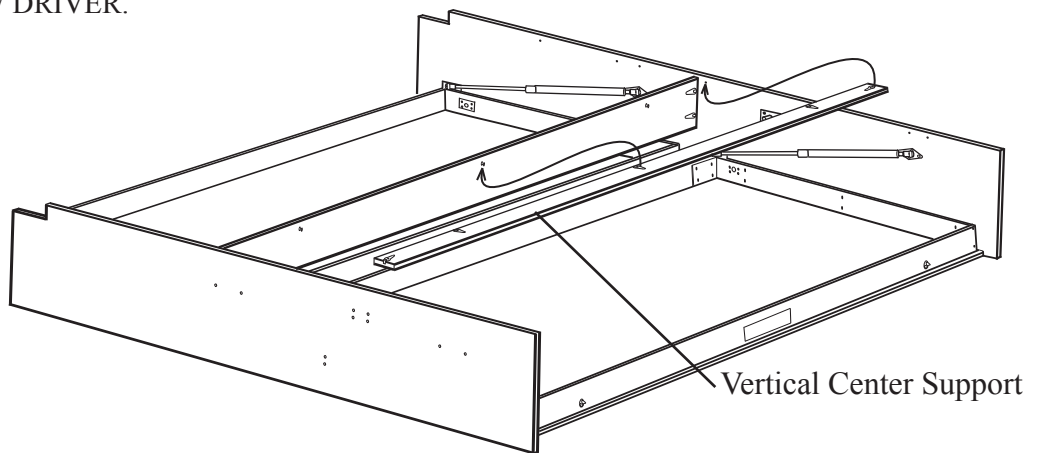

Step 15: Insert the upper and lower head boards as illustrated and tighten the cam fittings. Do this procedure by hand DO NOT USE A POWER SCREW DRIVER.

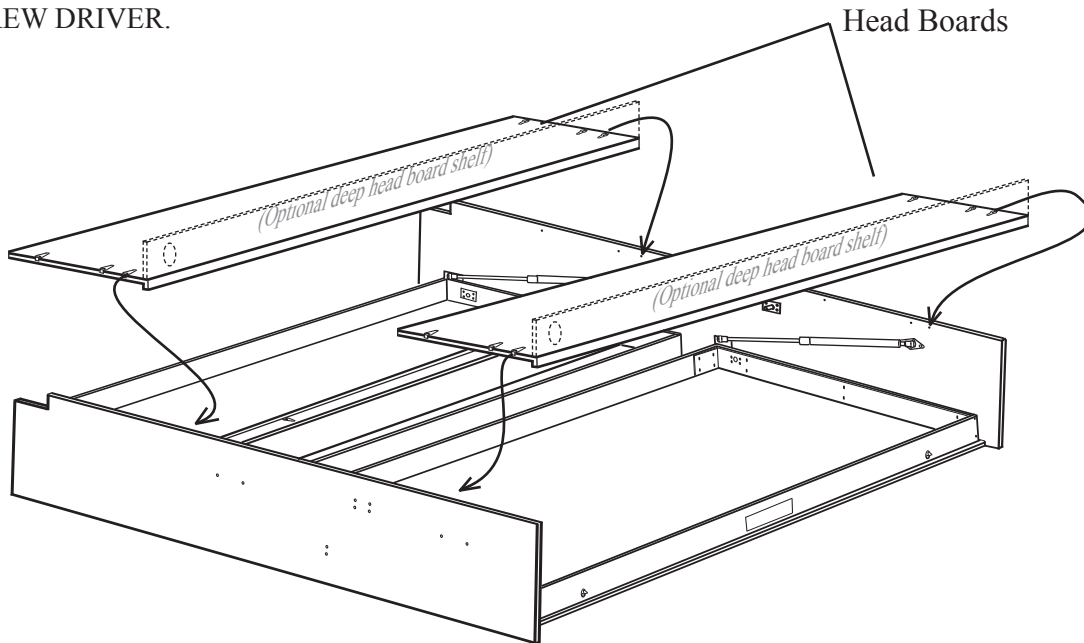

Step:16 This step will require at least 2 people. From the top of the bunk bed lift it up to the standing position. Make sure to support the UPPER bunk and side boards together as you lift. The LOWER bunk MAY open as you lift the bunk bed to the standing position. Be careful, the bunk bed fronts are heavier and the unit may not stand on its own.

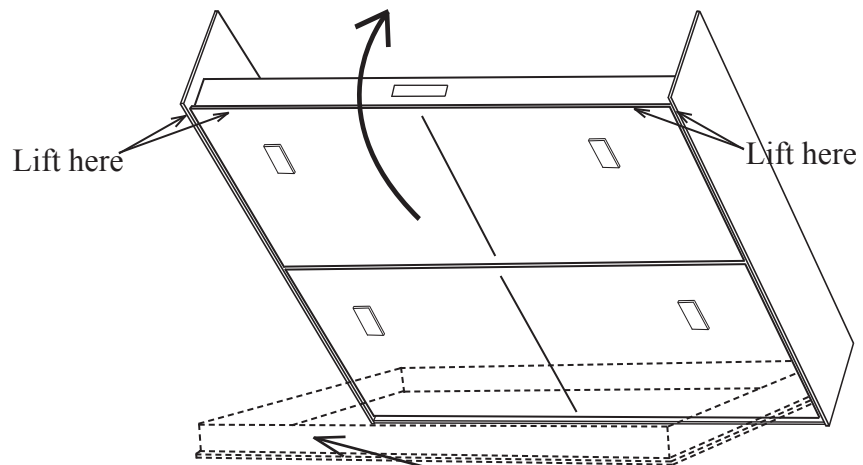

Important Note:
Leave the bunk bed unit a couple feet away from the wall so you can get behind it in a later step.

Helpful hint: The lower bunk may open as you lift bunk bed to the standing position.

Step 17 Place the bridge board on the top of the bunk bed. The bridge board has slots provided that accept the side boards. Line the front edges of the bridge board up with the side boards.

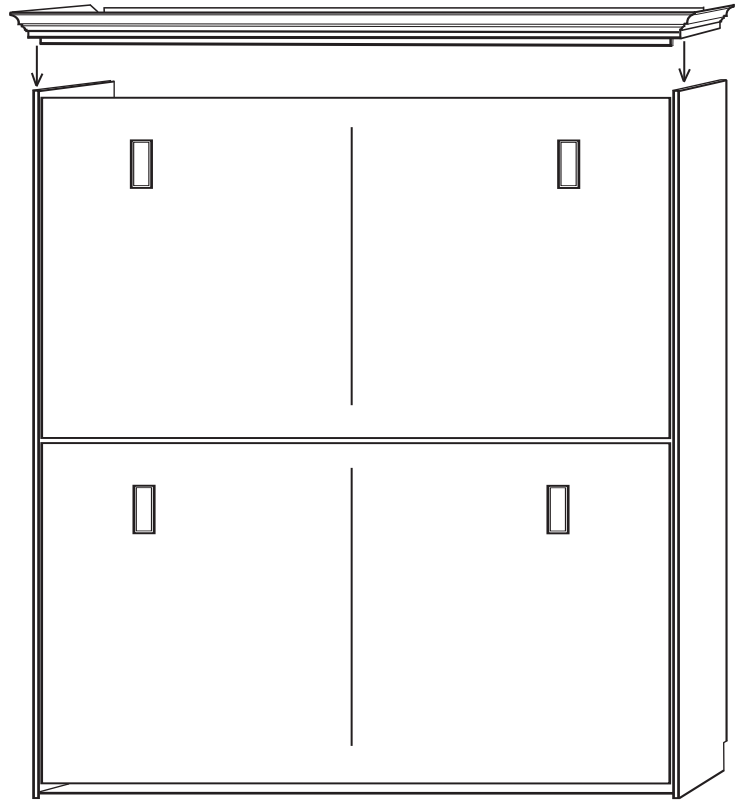

Step 18: From the back of the bunk bed attach the bridge to the side boards using three (on each side) 1 1/2" screws. Place the screws through the holes provided in the corner blocks on the bridge board and drive them into the side boards.

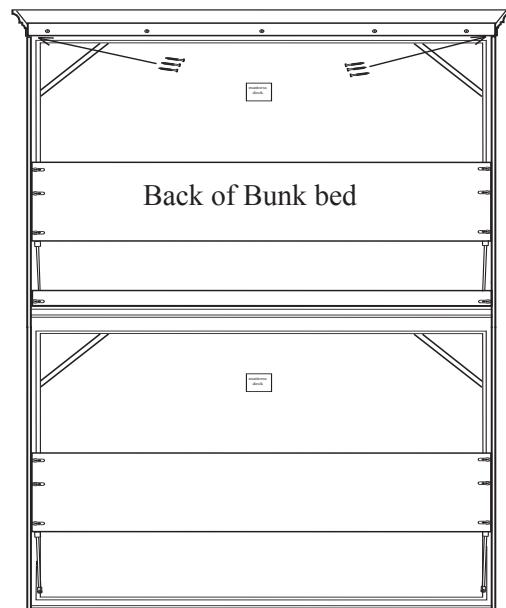

WARNING: THE NEXT 2 STEPS MAY REQUIRE PROFESSIONAL HELP.

FAILURE TO PROPERLY ANCHOR WALLBED TO YOUR WALL COULD CAUSE THE BED TO FALL AND SEVERE PERSONAL INJURY COULD RESULT. CALL TECHNICAL SUPPORT AT 866-877-7803 IF YOU HAVE ANY QUESTIONS.

Step 19: Slide the bunk beds against the wall into the position where it will be installed. Standing on a ladder in front of the beds, locate the studs in your wall with a stud finder, then mark them with a pencil just above the anchor board located at the back of the bridge board. You should find at least 3 to 4 studs. It is **HIGHLY** recommended that you run a test screw or small nail into your wall just above the anchor board to verify that you have found the stud location. **IF YOUR WALLS ARE NOT TRADITIONAL WOOD FRAMING, YOU MAY NEED TO HIRE A HANDY MAN OR CONTRACTOR TO HELP IN ANCHORING THE BED SECURELY TO YOUR WALL.**

Step 20: Using a 1/4" drill bit (provided) **PRE-DRILL HOLES** through the anchor board that correspond with the studs in your wall **DO NOT PRE-DRILL THE STUDS**. Now, using 3 1/2" Screws, anchor your bed to the wall.

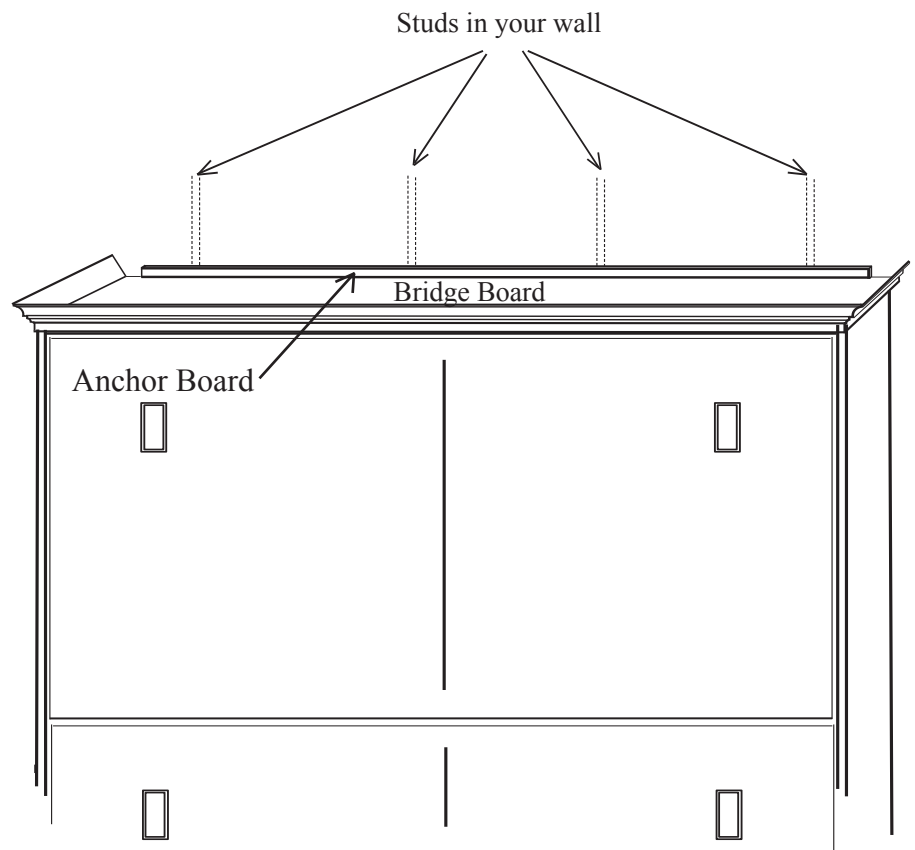

Step 21: Replace the bed bumpers that were removed in an earlier step. Re-attach the solid wood base mold with small “L” brackets attached to the back. (Chalet and Silhouette style beds do not have base mold). Position the base mold at the bottom of the bunk bed and centered. Have someone partially open the lower bunk so you can access the “L” brackets. Using screws provided attach the base mold to the stretcher board.

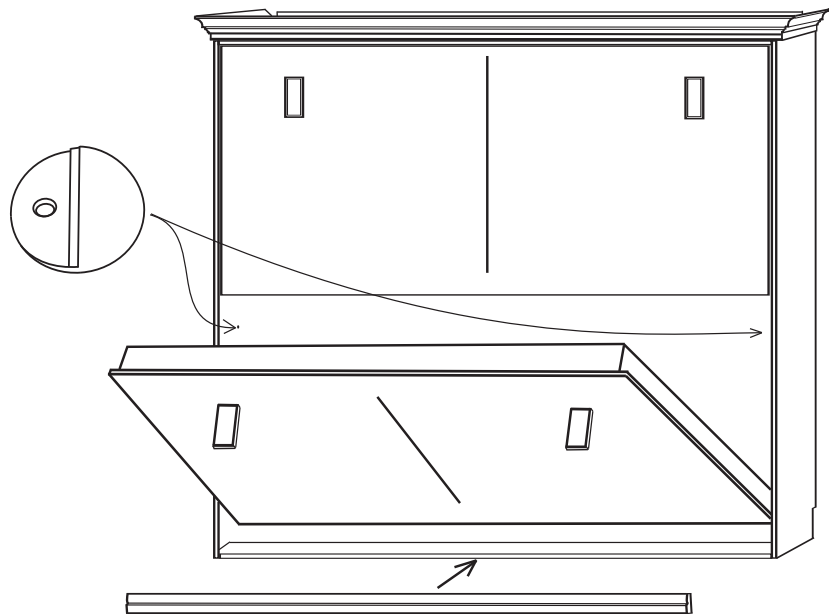

Step 21: Position the upper bunk guardrail on the INSIDE of the mattress box and attach it to the mattress box using the hardware provided.

WARNING!!

UPPER BUNK MUST HAVE GUARDRAIL PERMANENTLY INSTALLED. FAILURE TO INSTALL AND USE GUARDRAIL COULD RESULT IN A SERIOUS FALL.

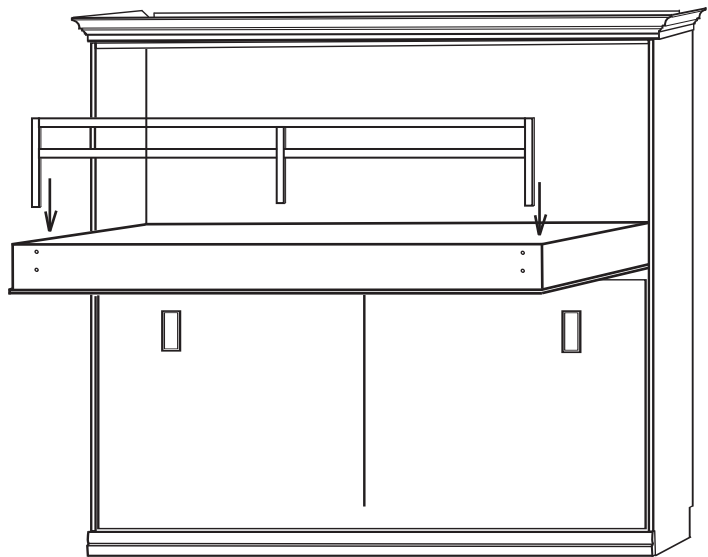

WARNING!!

TO HELP PREVENT SERIOUS OR FATAL INJURIES FROM ENTRAPMENT OR FALLS

- Never allow a child under 12 years old on upper bunk.
- Use only mattress which is 74”- 75” long and 37”- 38” wide.
- Ensure thickness of mattress does not exceed 9” and mattress is at least 5” below upper edge of guardrail.

- Use guardrail on front side of upper bunk.
- Prohibit horseplay on or under bed(s).
- Prohibit more than one person on upper bunk.
- Use ladder for entering and leaving upper bunk.

STRANGULATION HAZARD – Never attach or hang items to any part of the bunk bed that is not designed for use with the bed: for example, but not limited to, hooks, belts and jump ropes.