

WILDING WALLBEDS INSTALLATION INSTRUCTION

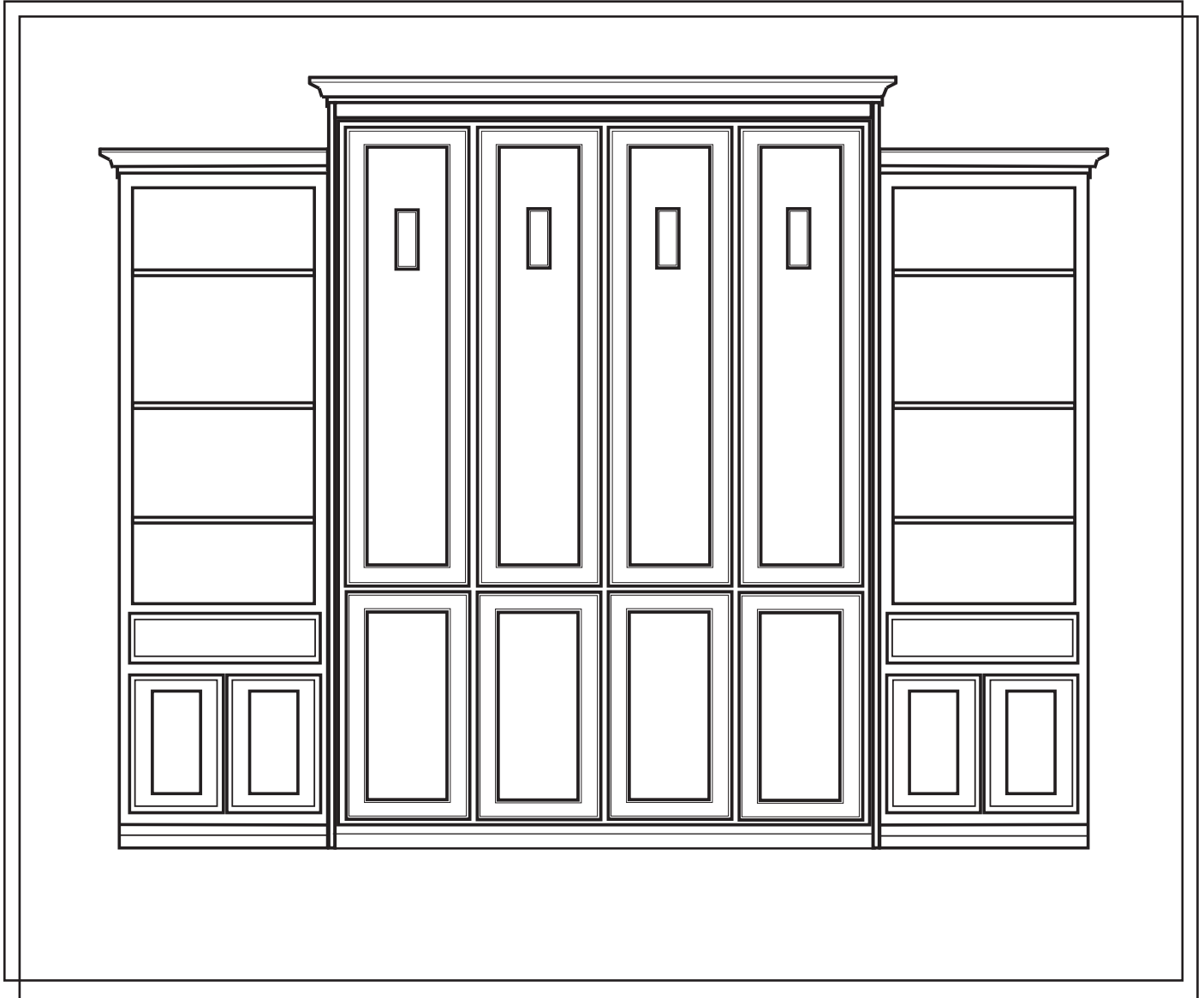



INSTRUCTION BOOKLET #10

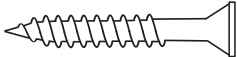

WARNING! ALL MURPY/WALLBED SYSTEMS CONTAIN POWERFUL LIFTING COMPONENTS . FAILURE TO USE AND FOLLOW THESE INSTRUCTIONS DURING THE INSTALLATION PROCESS COULD RESULT IN SEVERE PERSONAL INJURY TO USER OR DAMAGE TO PRODUCT. PLEASE CONTACT CUSTOMER SERVICE AT 866-725-6401 FOR ANY QUESTIONS.

Revision 9/10 BK10

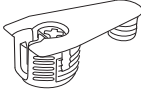
Hardware Supplied

QTY	SIZE	
3	3 1/2" Grabber	
6	1 1/4" Grabber	
4	1 1/4" Pocket Hole Screw	
6	Cam Fitting (extras)	
6	Connecting Bolt (extras)	

Tools Needed

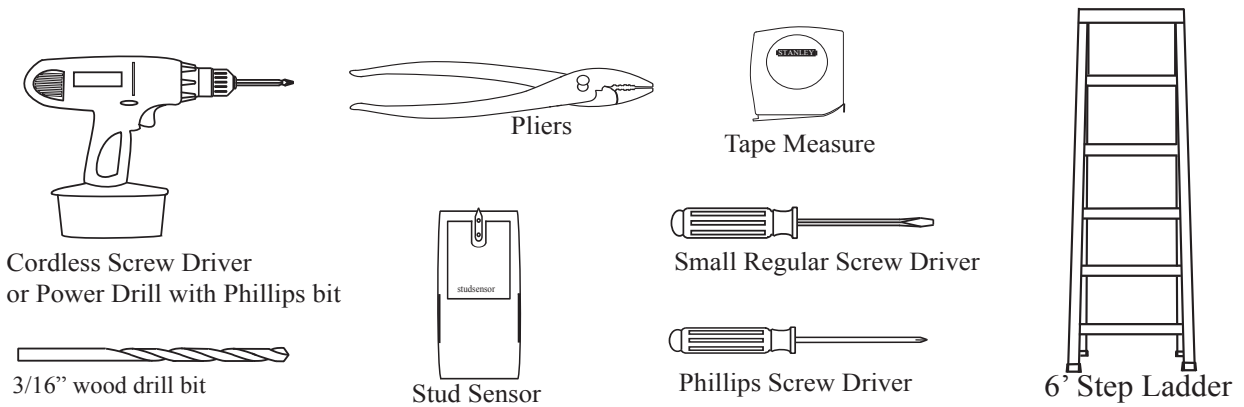

Wall Bed Components

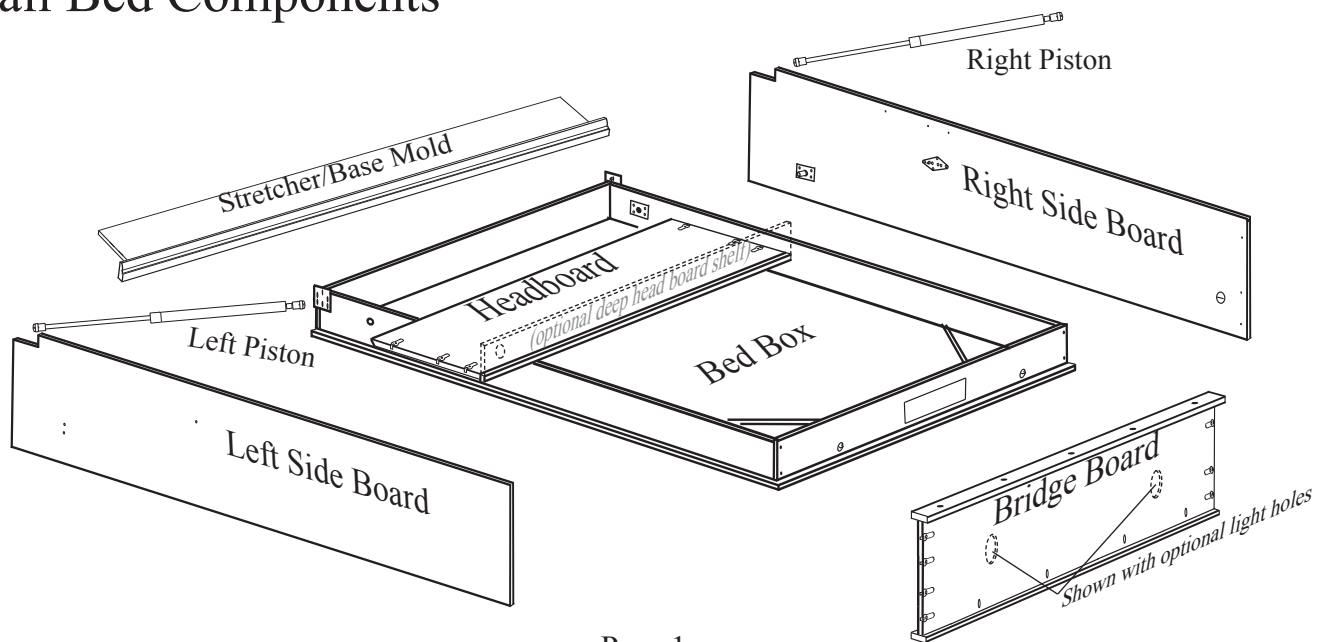

Side Board Illustration

For ease of assembly, familiarize yourself with side board parts below.

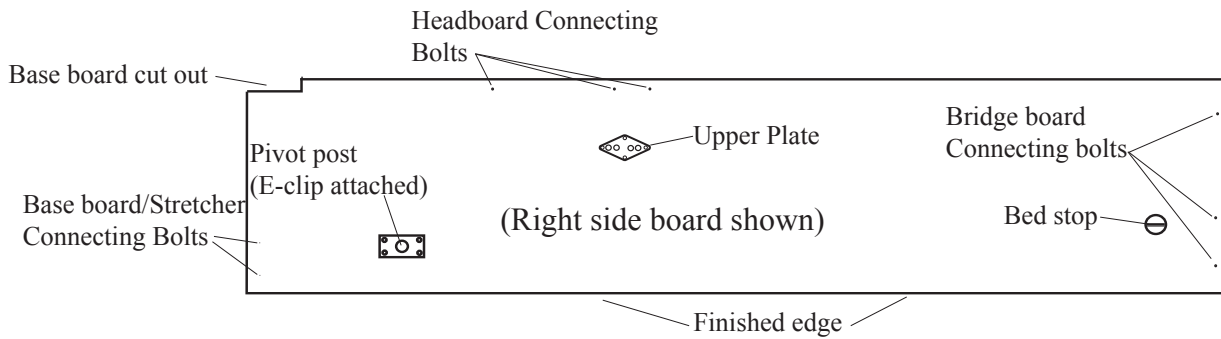

Step 1: Position the Bed Box and the right and left Side Boards face down with the bottom of the bed approximately 2 feet from the wall the bed is to be installed on. (Illustration 1)

CAUTION: If your floor is hardwood, tile, or any other hard type flooring, place a blanket down first to protect the bed front from scratches.

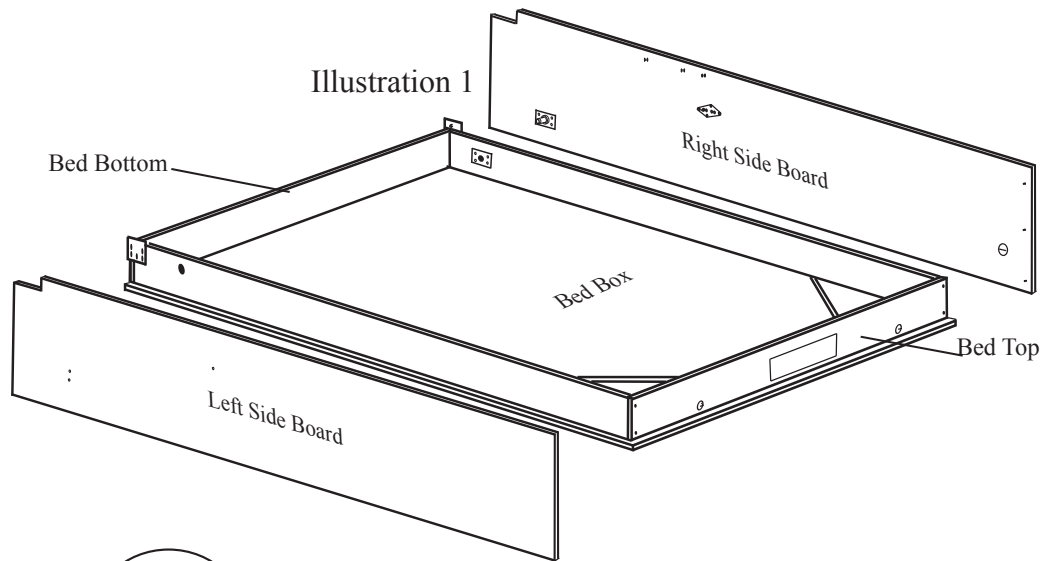

Step 2: With a pair of pliers, or a small regular screw driver, remove the E-clips from pivot posts on the side boards. Leave the white nylon spacers in place on the pivot posts.

Step 3: Slide the Side Board pivot posts through the pivot holes in the Bed Box as shown in illustration 2. Then replace the E-clips by snapping them back onto the pivot posts in groove provided.

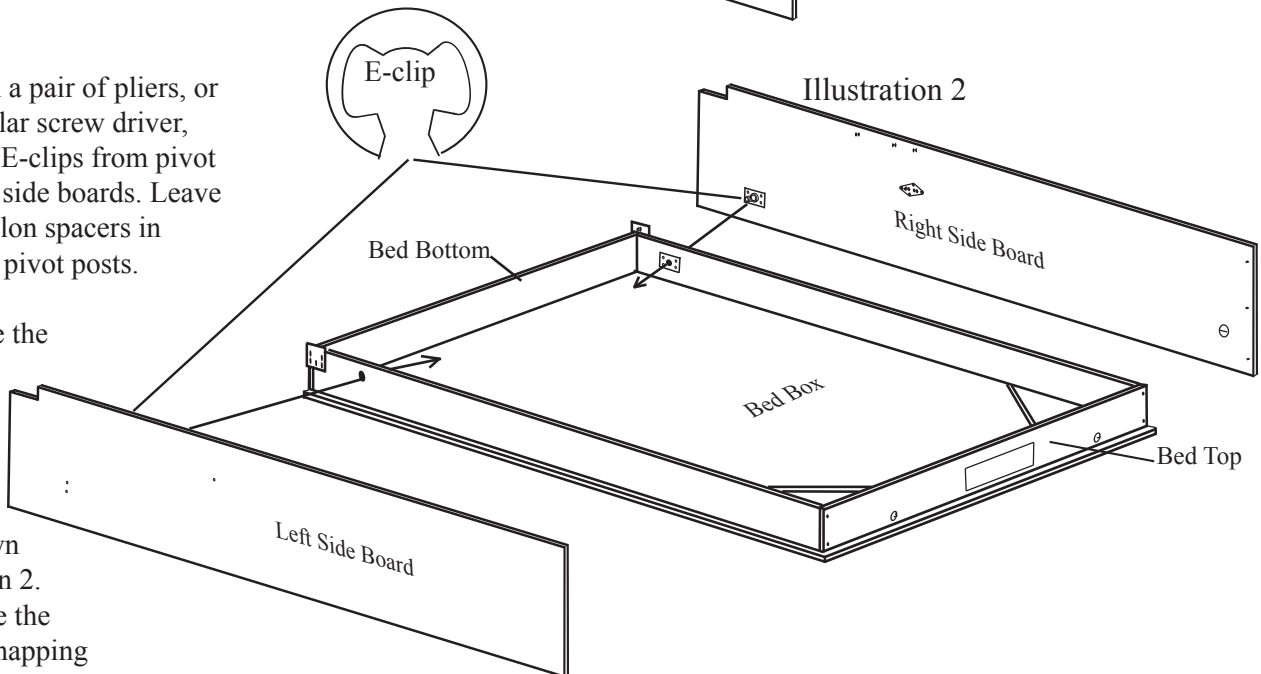

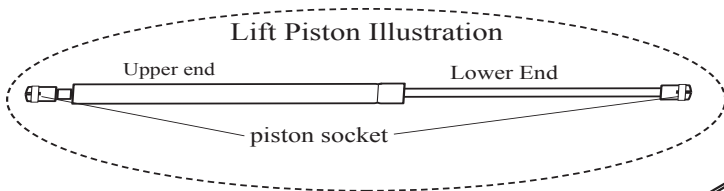

Step 4: Attach the lower end of the LIFT PISTON (skinnier end) onto the LOWER ANCHOR PLATE on both sides of the bed box by positioning the socket end of the piston directly over the anchor ball on the anchor plates and pushing them on. The piston socket should snap into place over the anchor ball.

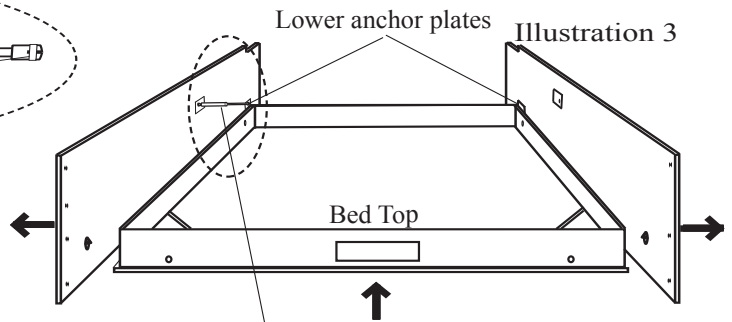

Step 5: Spread out the Side Board tops so the Bed Box has clearance to pass through the Bed Stops on the Side Boards. (See illustration 3)

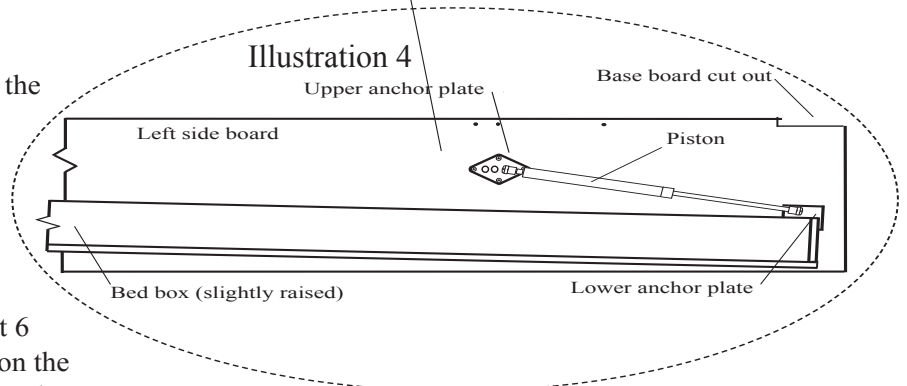

Step 6: This step will require two people. One person will need to kneel down in front of the Bed Box and lift it up about 6 to 7 inches. The second person will position the upper socket end of the LIFT PISTON directly over the anchor ball on the upper anchor plate and snap it into place. The first person may need to raise and lower the Bed Box slightly to allow the Piston to snap on. Repeat step 6 for opposite piston to be snapped into place. (Illustration 4)

Step 7: Position the Bridge Board by inserting the 3 connecting bolts on the right Side Board into the 3 Cam Fittings on the right side of the Bridge Board and tighten the Cam fittings using a Phillips screw driver and turning them clockwise. Do this procedure by hand to insure the Cam fittings are tight but not over tightened. DO NOT USE A POWER SCREW DRIVER. Once the Cam fittings are tight insert two (per side) pocket hole screws into the Pocket Holes and screw them into the Side Boards.

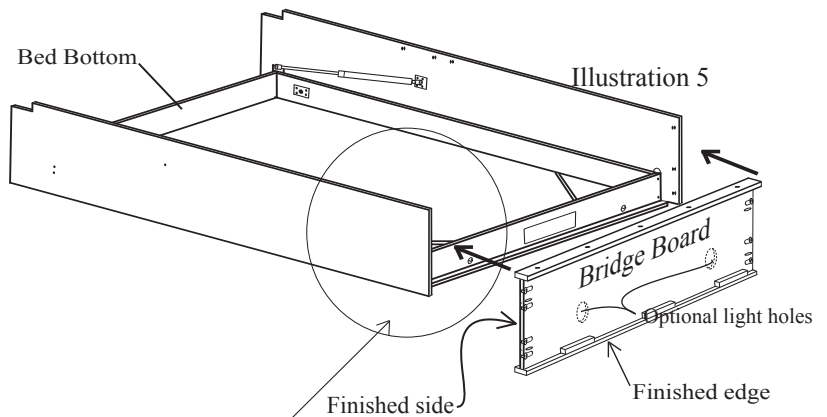

Step 8: The process will be repeated on the left side of the Bridge Board but it will be necessary to place the BED STOPS on the edges of the Bed Box so the Bridge Board and the left Side Board will pull together.

Helpful Hint: after attaching ONE side of the Bridge Board to the Side Board it will be easier to attach the second side by lifting both Side Boards and the Bridge Board above the Bed Box and then insert the Connecting Bolts into the Cam fittings.

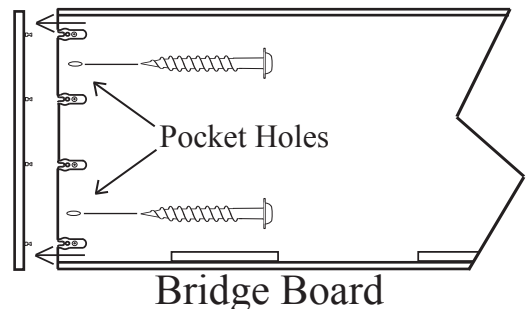

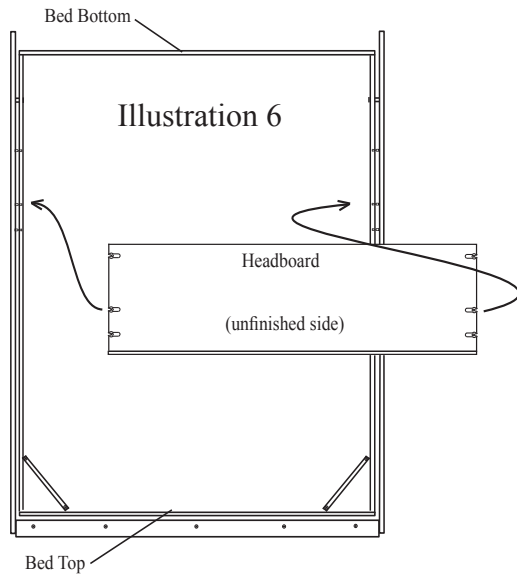

Step 9: With the bed still laying face down on the floor the Headboard can be installed. **HAVE SOMEONE HELP WITH THIS STEP.** Line up one side of the Headboards Cam fittings with the connecting bolts on the side board and hold it in place while the second person gently pulls out ward on the opposite Side Board until the Headboard will pass the other set of connecting bolts. Make sure the unfinished side of the Headboard is facing up, or that you are looking at the unfinished side of the Head Board as you position it. Now with a Phillips screw driver tighten the Cam fittings by turning them clockwise. Do this procedure by hand **DO NOT USE A POWER SCREW DRIVER.** (See illustration 6)



IF YOU PURCHASED A LIGHT KIT FOR YOUR WALL BED YOU MUST INSTALL LIGHT SYSTEM AT THIS POINT

Refer to instructions in the light kit box for installation

Step:10 Separate the Stretcher and Base mold by removing the screws from the Stretcher **LEAVE THE "L" BRACKETS ATTACHED TO THE BASE MOLD.**

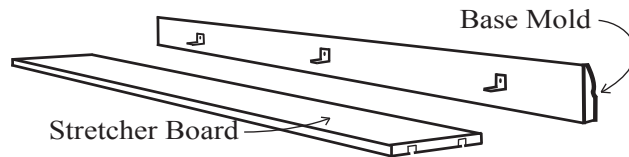

NOTE: Chalet and Silhouette models have no Base Mold.

Step 11: Locate the Stretcher Board and slide it between the Side Boards at the bottom of the Wallbed. Insert the Connecting Bolts into the Cam fittings and tighten them by turning the cam clockwise. Do this procedure by hand **DO NOT USE A POWER SCREW DRIVER.** (See illustration 7)

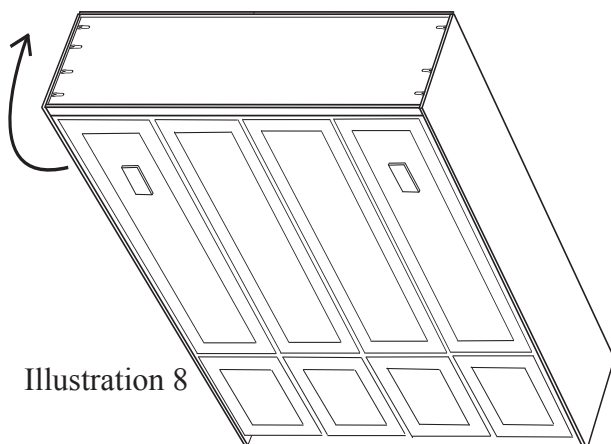
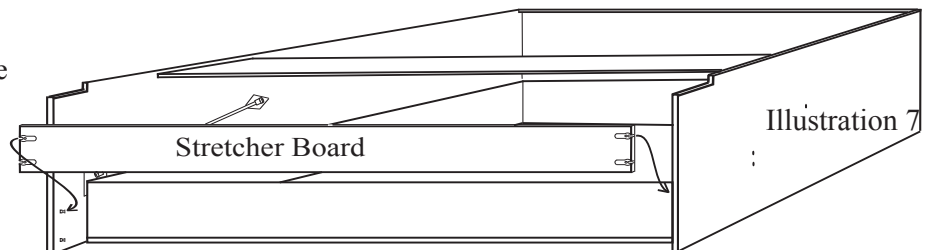

Step:12 This step will require 2 people. From the top of the bed lift it up to the standing position. Be careful, the bed front is heavier and the bed may not stand on its own. (Illustration 8)

Step 13: Once the bed is standing up, slide it back and position it against the wall where it is to be installed. Check the gap between the Side Boards and the Bed Front on both sides. The gap at this point will probably need to be adjusted. You can adjust the gap by pushing the bed to one side or the other at the top of the bed. Pushing it will even out the gap from top to bottom on each side. At this point don't worry if one side has a larger gap than the other as long as each side's gap is about the same from top to bottom. (Illustration 9)

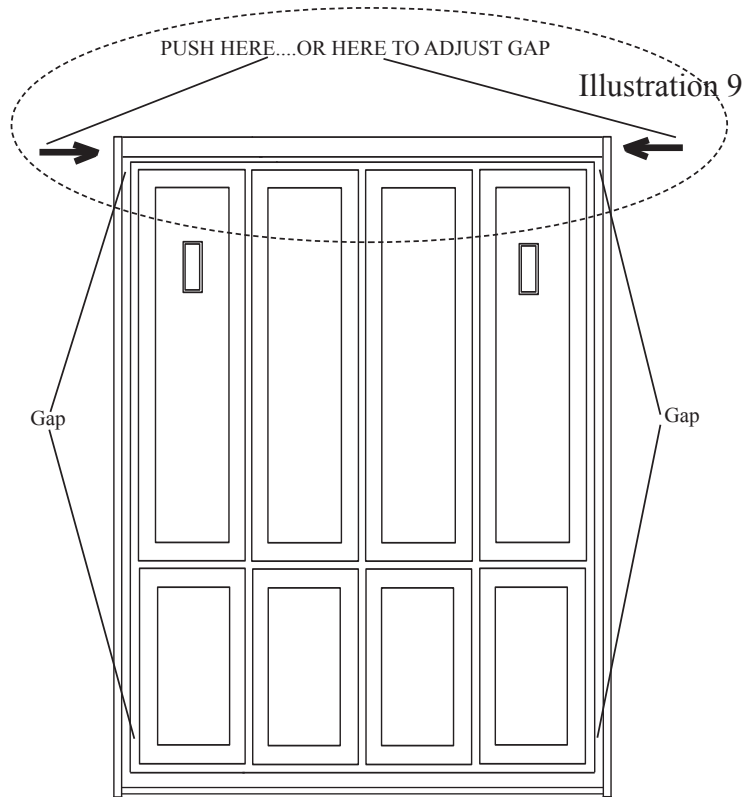

WARNING: THE NEXT 2 STEPS MAY REQUIRE PROFESSIONAL HELP.

FAILURE TO PROPERLY ANCHOR WALLBED TO YOUR WALL COULD CAUSE THE BED TO FALL AND SEVERE PERSONAL INJURY COULD RESULT. CALL TECHNICAL SUPPORT AT 866-877-7803 IF YOU HAVE ANY QUESTIONS.

Step 14: Standing on a ladder in front of the bed, locate the studs in your wall with a stud finder, then mark them with a pencil just above the Anchor Board located at the back of the Bridge Board. (See illustration 10) You should be able to find at least 3 studs for Queens and Fulls, Twin size beds require 2. It is highly recommended that you run a test screw into your wall just above the Anchor Board to verify that you have found the stud location. IF YOUR WALLS ARE NOT TRADITIONAL WOOD FRAMING, YOU MAY NEED TO HIRE A HANDY MAN OR CONTRACTOR TO HELP IN ANCHORING THE BED SECURELY TO YOUR WALL.

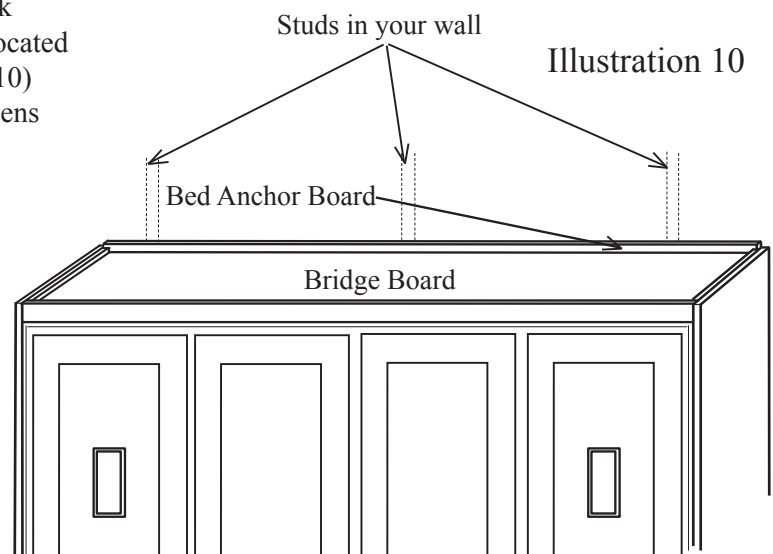

Step 15: Using a 1/4" drill bit pre-drill holes through the Anchor Board that correspond with the studs in your wall DO NOT PRE-DRILL THE STUDS. Now, using 3 1/2" Screws, anchor your bed to the wall.

Illustration 11

Step 16: Open the legs on the front of the bed by gripping the bottom of the leg and lifting them up. THEN REACH YOUR FINGERS INTO THE OPENING UNDER THE LEG AND PULL THE BED TOWARD YOU. Open and close the bed a couple of times so the bed will align. You don't need to lower the bed all the way to the floor, just open it about as far as illustration 11 illustrates.

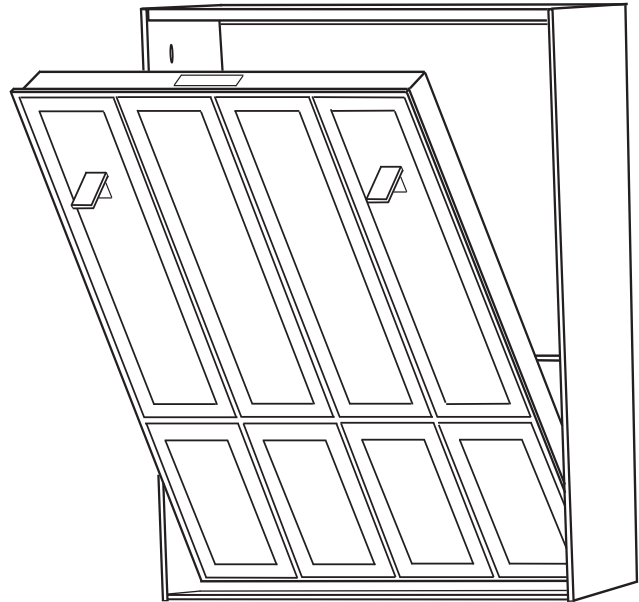

Illustration 12

Step 17: Check the gap alignment again. If it looks right skip this step. If the gap is not right, meaning that the Bed Box is too close to the side board or even touching it at the top on one side. It can be adjusted even after the Bed is attached to the wall but it will require two people. The procedure will require the bottom of the bed to be moved slightly to the left or right depending on which top corner is too close. If the bed is too close on the top right side for instance the right side (bottom) will need to be slid to the left slightly (See illustration 12). Have one person push the bed at the bottom with his feet while the second person pulls at the opposite bottom side.



← Push bed over at bottom to align

Step 18: Locate the solid wood Base Mold with small “L” brackets attached to the back. (Chalet and Sihloette style beds do not have base mold). Position the Base Mold at the bottom of the Wallbed and centered. Have someone partially open the Wallbed so you can access the “L” brackets. Using three 3/4” pan head screws attach the Base mold to the Stretcher Board.

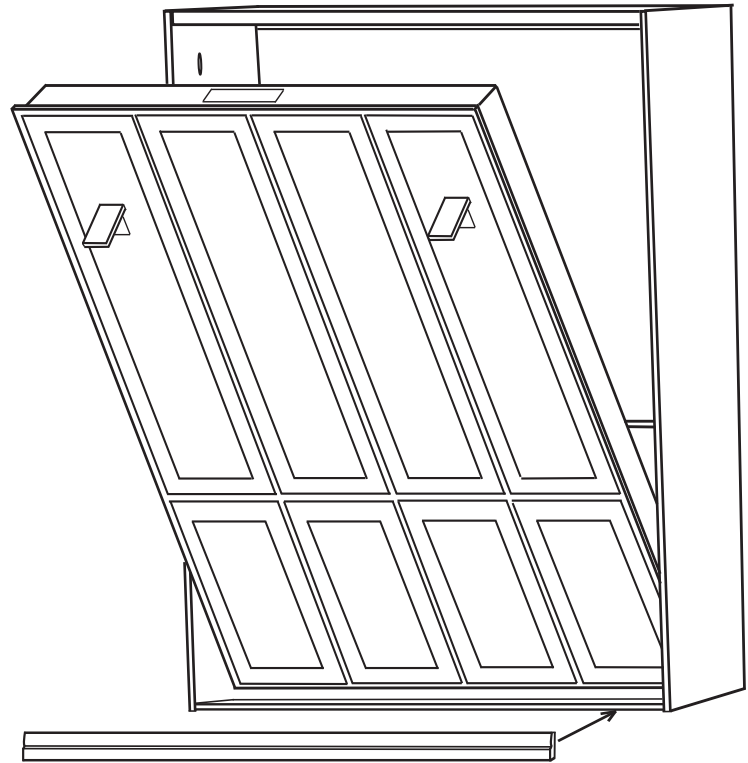

Step 19: (For all beds except the Chalet) Place the Wall Bed crown mold on top of the Wall Bed and use six 1 1/4” gold screws to attach the crown mold. As you screw the crown mold in place push it in so it fits tight against the bed. (Illustration 13)

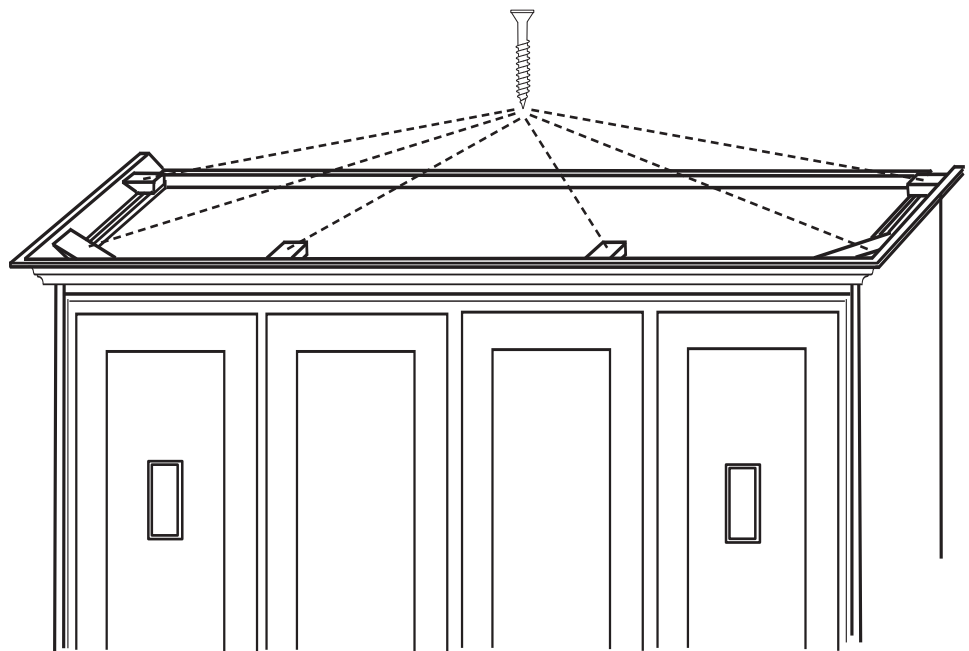
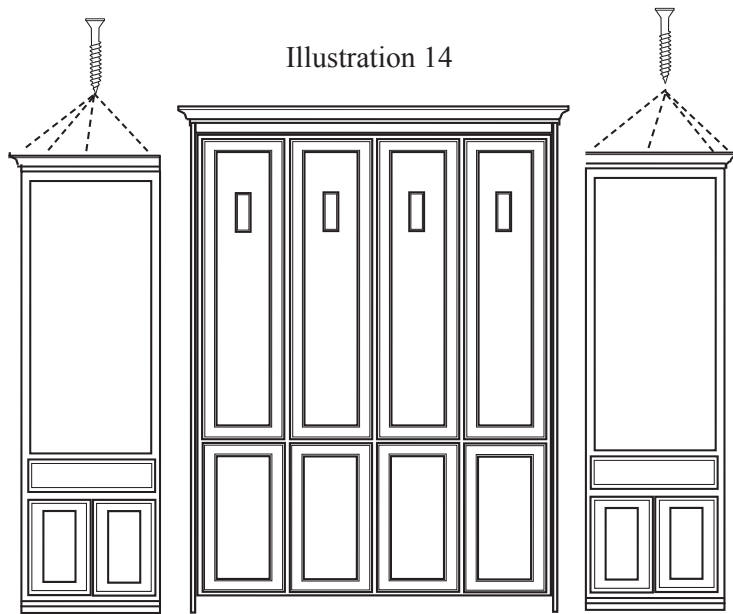

Illustration 13

Step 20: Attach the crown mold to the side cabinets as you did on the Wall Bed (see illustration 14). (Chalet side cabinets have no crown). The Crown Molding packaged in the respective Side Cabinet is designed to fit that particular Cabinet. Side cabinets are designed as a Left and Right and will typically be marked as such on the back of the cabinet. If you are unsure which cabinet is left and which is right, look at the sides of the cabinets and one side will typically look better than the other.



NOTE: It is recommended to attach the side cabinets to the bed so they fit tight to the bed and are secured properly.

Step 21: Anchor the Side Cabinet to the Bed by first pre-drilling three 3/16" holes at the inside edge of the side cabinet. Position the holes close to the front edge of the side cabinet just behind the Face Frame. One hole should be near the top, one should be inside the drawer area (remove drawer from cabinet to get to this one), and the third should be at the bottom (open door if your cabinet has door, or remove drawer at bottom) for this hole. (See illustration 15)

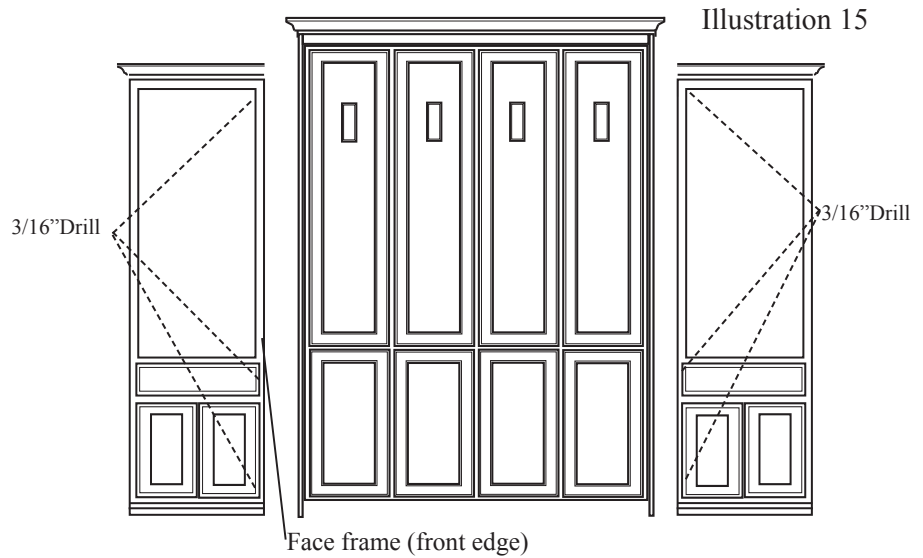

Step 22: Move the side cabinets next to the bed and use three 1 1/4" Gold Screws through pre-drilled holes to anchor Side Cabinets to the Bed's Side Boards. (See illustration 16)

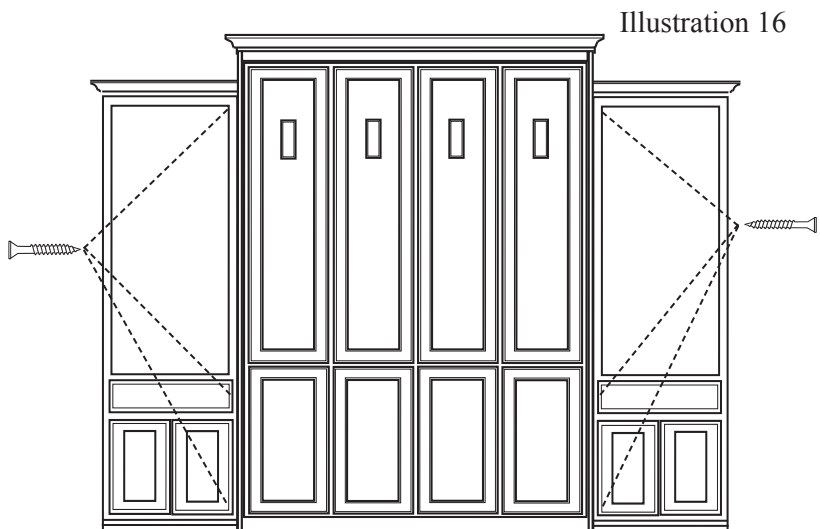

Step 23: Insert Gold Shelf Supports at desired location in Side Cabinets then place shelves. (Wardrobes don't have adjustable shelves).